

Technical Service Bulletin



Of Interest General Manager Sales Manager Service Manager Parts Manager Service Technicians

March 11, 1969

No. D69-19-4

The following information supplements the 1967 through 1969 Dart, Coronet, Charger and Polara/Monaco Service Manuals and is designed to assist the technician in servicing steering columns.

Whenever a steering column or steering gear is serviced or disturbed this bulletin should be referred to.

POLICY: INFORMATION ONLY

R. H. KLINE
Manager - Service
DODGE DIVISION

STEERING

Service
Manual
Supplement

MODELS: All
1967 Through
1969 Dodge
Models

P-830

(THIS BULLETIN IS SUPPLIED AS TECHNICAL INFORMATION ONLY AND IS NOT AN AUTHORIZATION FOR REPAIRS)
REPRINT OF THIS MATERIAL NOT AUTHORIZED UNLESS APPROVED BY MANAGER OF SERVICE, DODGE DIVISION



Dart/Coronet/Polara/Monaco/Charger

After a steering column has been removed, reconditioned or disturbed due to service performed on the column or adjacent vehicle components, certain precautions must be observed when installing the column or servicing the steering shaft coupling.

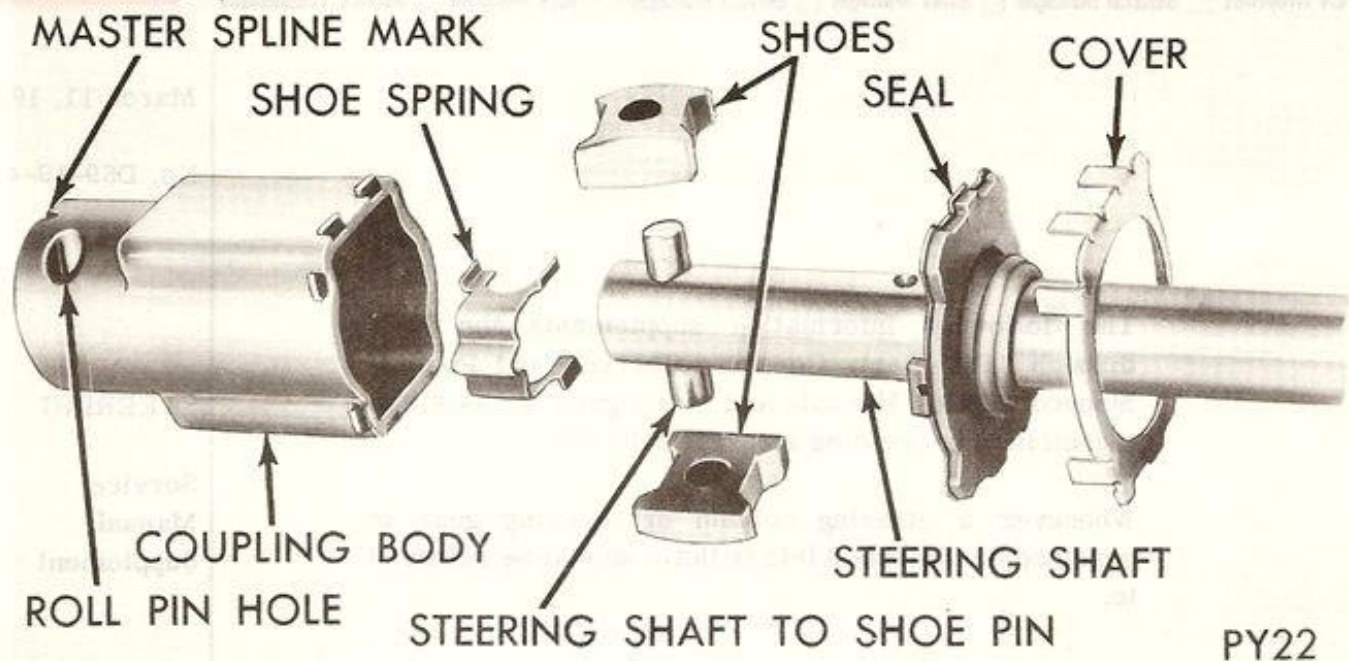

PY22

FIGURE 1. STEERING SHAFT COUPLING DISASSEMBLED

ASSEMBLY OF STEERING SHAFT COUPLING (FIGURES 1 AND 2)

The grease recommended for use during assembly procedure is Automotive Multi-Purpose Grease NLGI Grade 2 E.P. or Multi-Mileage Lubricant, Part No. 2525035.

1. Fill coupling body to 1/2" from top.
2. Place seal cover and seal on steering shaft.
3. Press the shoe pin into the steering shaft so that it projects an equal amount on each side of steering shaft.
4. Place spring on side of shaft, straddling the shoe pin.
5. Place shoes on pin ends. Flat side toward spring engaging tangs on spring.
6. Squeeze shoes together, compressing spring and push assembly into coupling body.
7. If body has dowel pin hole near cover, drive in a new pin, Part No. 9431620, flush to the outer surface.
8. Position seal and cover on body and crimp cover tangs over projections on body securely.

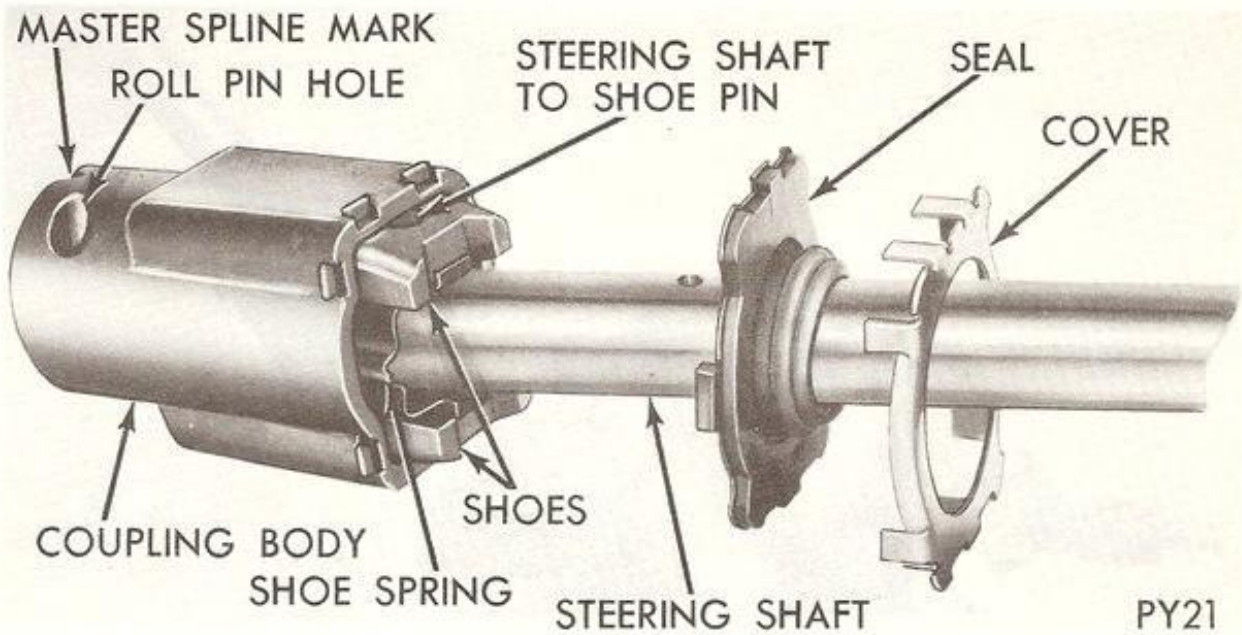

FIGURE 2. STEERING COUPLING PARTIALLY ASSEMBLED

The steering shaft coupling cover is designed to provide for permanent protection against the escape of lubricant and the entry of water, dirt or other contaminants.

It has been found that during any service to the steering column, steering gear or instrument panel where the column is lowered or disturbed, the coupling cover and seal may become dislodged. Once the cover has become loose, it is difficult to get a tight seal on re-installation or replacement of the cover. A SERVICE COUPLING COVER RETAINING CLAMP PART NO. 2996935 HAS BEEN RELEASED AND SHOULD BE INSTALLED WHENEVER THE COLUMN OR GEAR HAS BEEN DISTURBED FOR ANY REASON.

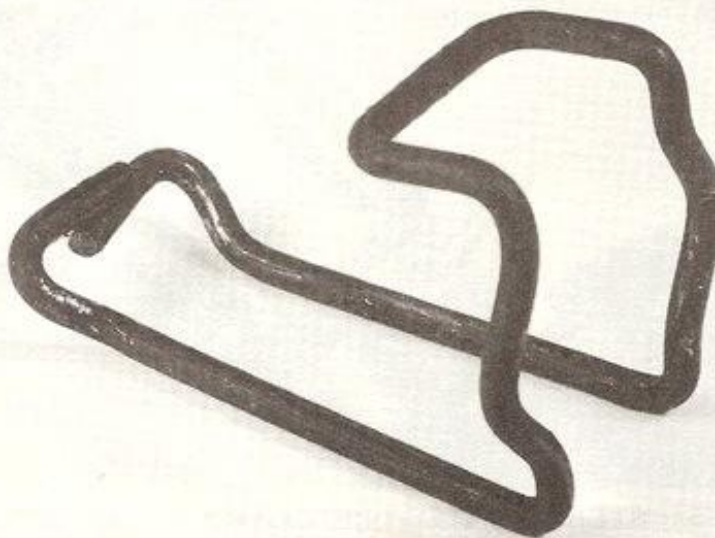

FIGURE 3. STEERING SHAFT COUPLING CLAMP

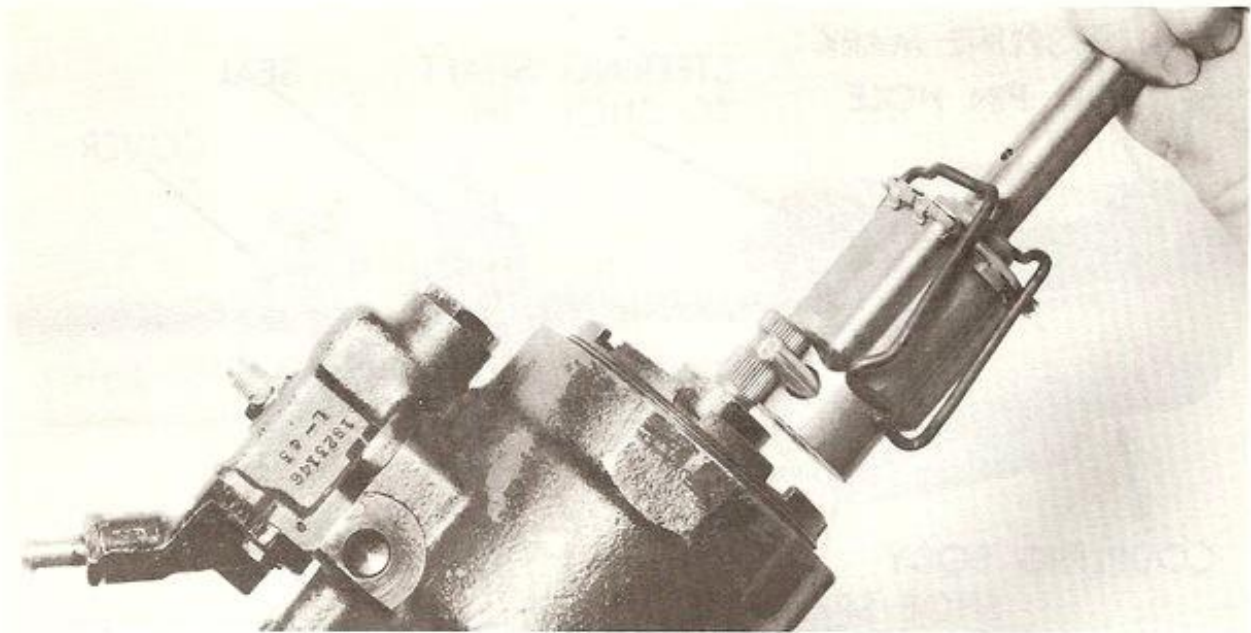

FIGURE 4. STEERING COUPLING TO GEAR ALIGNMENT

INSTALLATION OF STEERING SHAFT COUPLING COVER RETAINING CLAMP (FIGURES 3, 4, 5, 6 and 7)

1. Position clamp over cover next to steering shaft with long open legs downward. (Figures 4 and 5)
2. Spread leg ends over steering shaft.

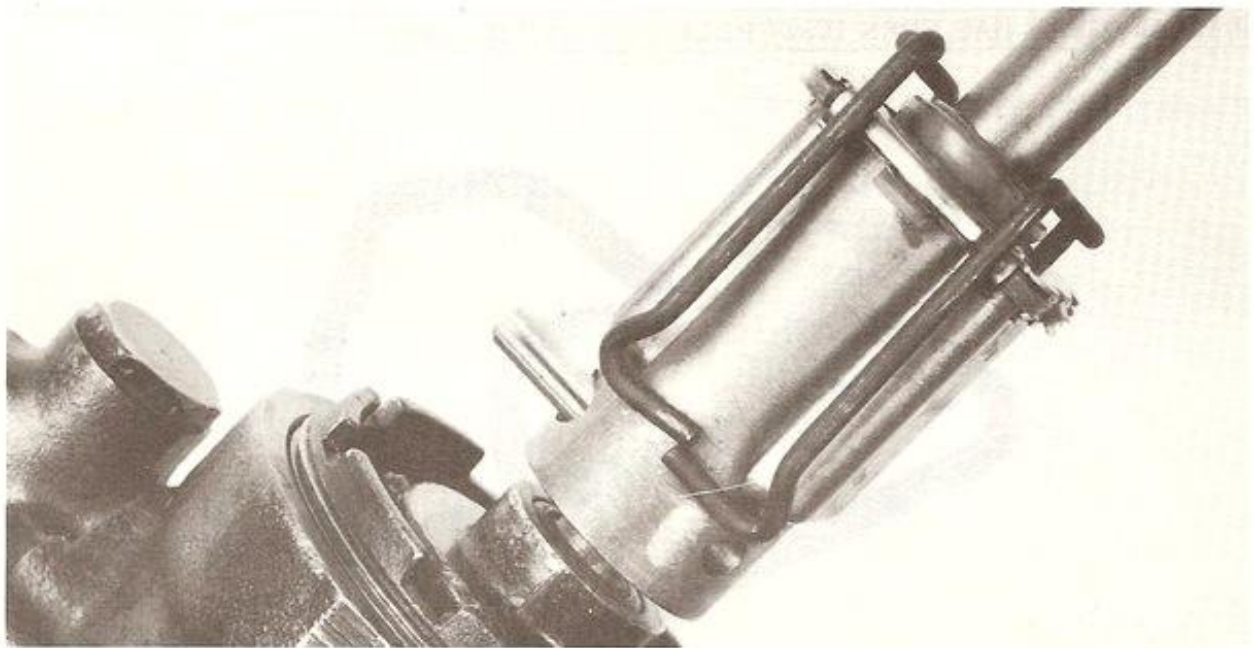

FIGURE 5. STEERING COUPLING CLAMP INSTALLATION

3. Rotate clamp so that long legs are on roll pin side of coupling. (Figure 4)
4. Force clamp down over cover. (Figure 5)
5. Place each leg end into the ends of the roll pin making sure the ends are fully seated into the roll pin. (Figures 6 and 7)

In addition to the clamp being serviced separately, it will be incorporated in the Coupling Repair Package Part No. 2800705 for manual steering, and Part No. 2800706 for power steering.

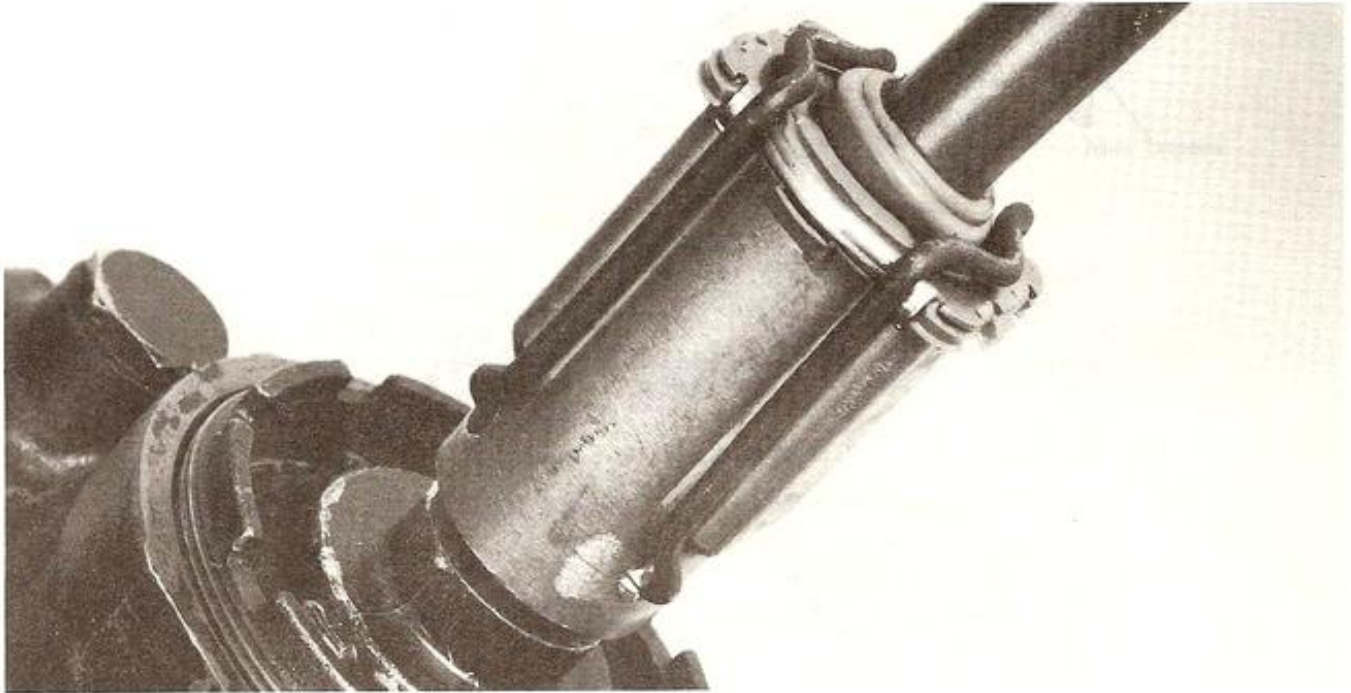

FIGURE 6. STEERING COUPLING CLAMP IN POSITION



FIGURE 7. STEERING COUPLING CLAMP IN POSITION

COLUMN INSTALLATION AND ALIGNMENT (FIGURES 8, 9 and 10)

1969 models only (refer to proper Service Manual for previous models).

1. Position bracket assembly on steering column and install and tighten the four short retaining screws to 120 inch-pounds. Insert column assembly through floor pan opening, being careful not to damage paint or trim.

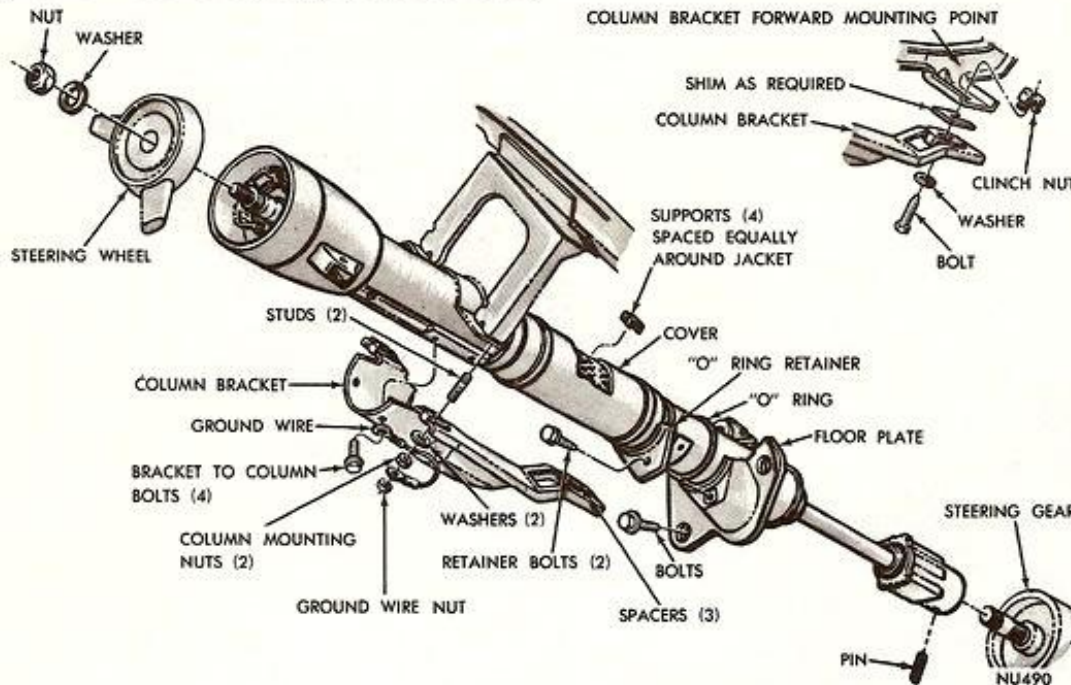

FIGURE 8. STEERING COLUMN MOUNTING

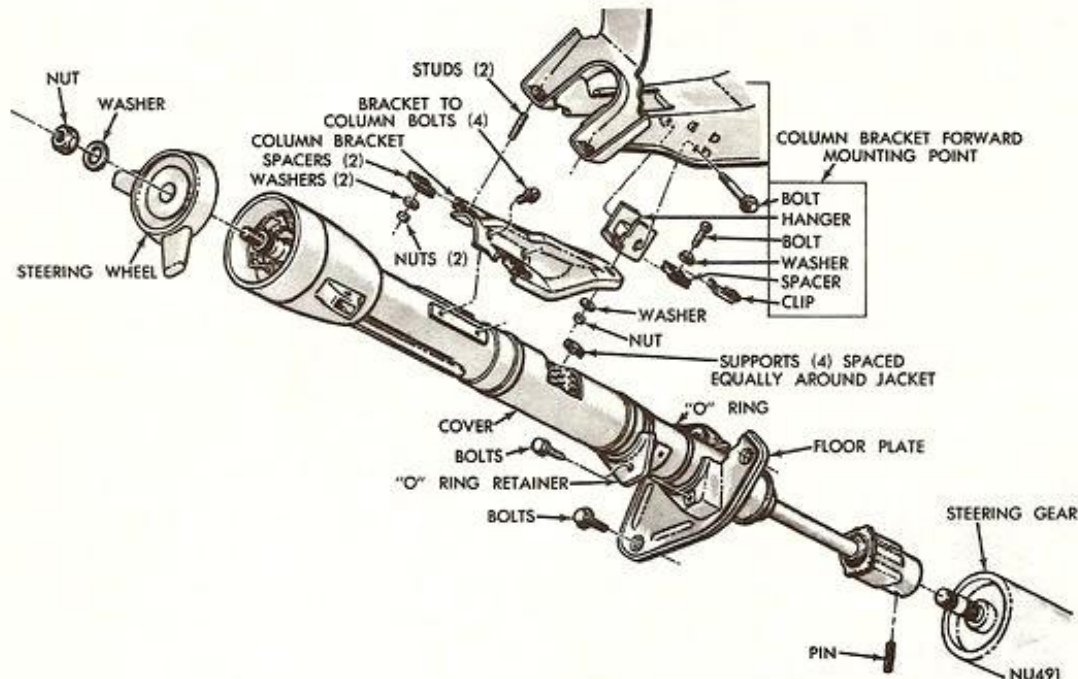

FIGURE 9. STEERING COLUMN MOUNTING

2. With front wheels in straight ahead position and master splines on wormshaft and coupling aligned, engage coupling with wormshaft and install the roll pin.
3. Hold column assembly with bracket against the instrument panel support. Install but do not tighten the two upper bracket nuts.
4. Center steering shaft coupling at midpoint of its travel. This is accomplished by moving column and bracket assembly fore and aft in the instrument panel support so dimension between top of coupling and center of gauge hole is $13/16$ inch (Figure 9). Tighten the two upper bracket nuts to 110 inch-pounds. Dart models with power steering have no gauge hole in the steering shaft. Measure from top of coupling to weld on steering shaft. Adjust to $3/8$ inch.

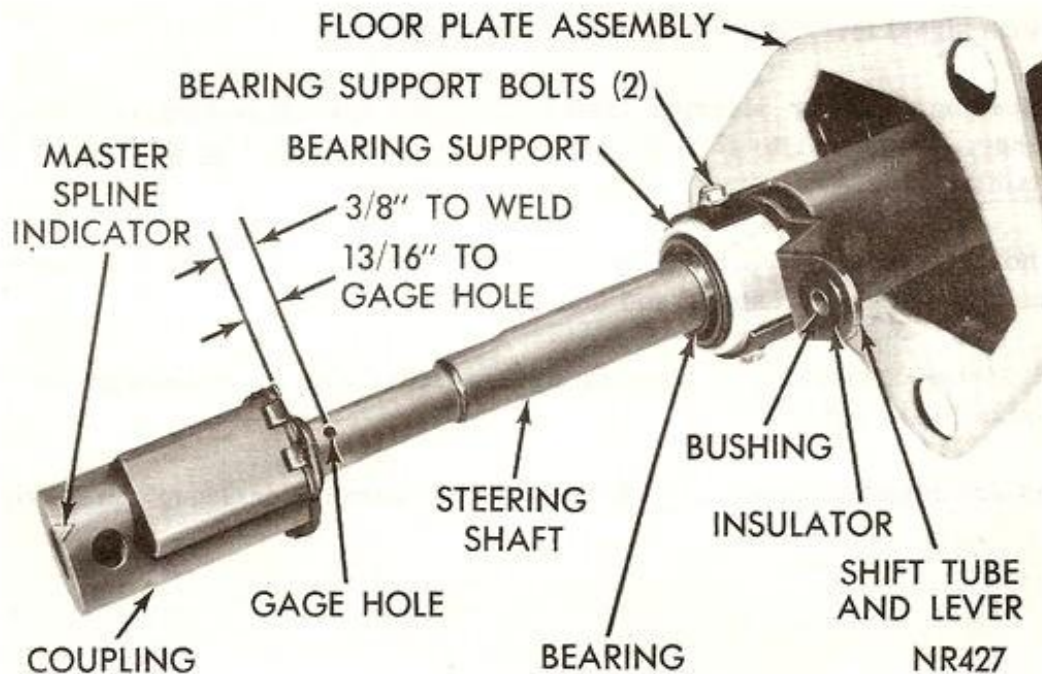

FIGURE 10. STEERING COLUMN COUPLING ALIGNMENT

5. Position floor plate over floor pan opening, centering it around the column, then install and tighten retaining bolts. Slide "O" ring down the jacket and into recess in floor plate, position retaining plate over "O" ring and secure with the two bolts. Do not pry to align plates and attaching bolts or column misalignment will occur.

6. Place shim pack between column bracket forward leg and instrument panel support. Maximum shim pack thickness error must not exceed .060 inch before tightening the bolt. Add shims, if necessary, then tighten bolt to 110 inch-pounds.

Loosen bolt attaching the forward adjustable hanger to the instrument panel support. Attach column bracket forward leg to the hanger and tighten to 110 inch-pounds. Then tighten the hanger to instrument panel support bolt to 200 inch-pounds.

7. Polara and Monaco: Connect gearshift indicator pointer to operating bracket on shift tube in its approximate original location. Slowly move gearshift lever from "L" (low) to "P" (park) pausing briefly at each selector position. The indicator pointer must align with each selector position. If necessary, loosen the bolt and re-adjust to align pointer correctly.
8. Attach finish plate to bottom of instrument panel.
9. Install turn signal lever and tilt lever if so equipped.
10. Place steering wheel on steering shaft with master splines aligned. Install retaining nut and washer, tighten nut to 27 foot-pounds. Do not drive wheel on shaft, draw wheel down with retaining nut.
11. Install horn switch parts previously removed from steering wheel. Connect horn switch wire. Install horn ring ornament and lock by turning clockwise.
12. Connect wiring connectors at steering column jacket. Connect battery ground cable, test operation of lights and horns.
13. Connect and adjust gearshift linkage; refer to "Transmission Group" in Service Manual.







FIGURE 2: STEERING COUPLING PARTIALLY ASSEMBLED

The steering shaft coupling cover is designed to protect the steering shaft and the entry of water, dirt and debris into the steering column. It has been found that during any service operation the steering column cover may become loose and become dislodged. When this occurs, the steering column cover should be replaced or replaced with a new cover. A SERVICE COUPLING COVER RETAINING COVER, PART NUMBER 299684, SHOULD BE INSTALLED WHEN THE COLUMN OR GEAR BOX IS REASSEMBLED TO PREVENT DISTURBANCE TO THE STEERING SYSTEM.

