

OCTOBER 1, 1974

DODGE

CORONET & CHARGER 1971-72

FRONT BUMPER & GRILLE

FRONT BUMPER & GRILLE, Cont'd.

CORONET

CHARGER

- R&I Bumper & Grille Assy. 1.0
- O/H Bumper & Grille Assy. 2.3
- Refinish Lower Panel 1.0

- w/Exposed Headlamps
 - R&I Bumper & Grille Assy. 1.0
 - O/H Bumper & Grille Assy. 2.3
 - Refinish Lower Air Panel 1.0
 - Lower Spoiler 1.0
- w/Concealed Headlamps
 - R&I Bumper & Grille Assy. 1.0
 - O/H Bumper & Grille Assy. #3.0
 - (#If Nec. to Transfer Riveted Brackets, Add 1.0
 - Time Incl. R&R Headlamp Doors & Actuating Motor
 - Refinish Lower Air Panel 1.0
 - Lower Spoiler 1.0

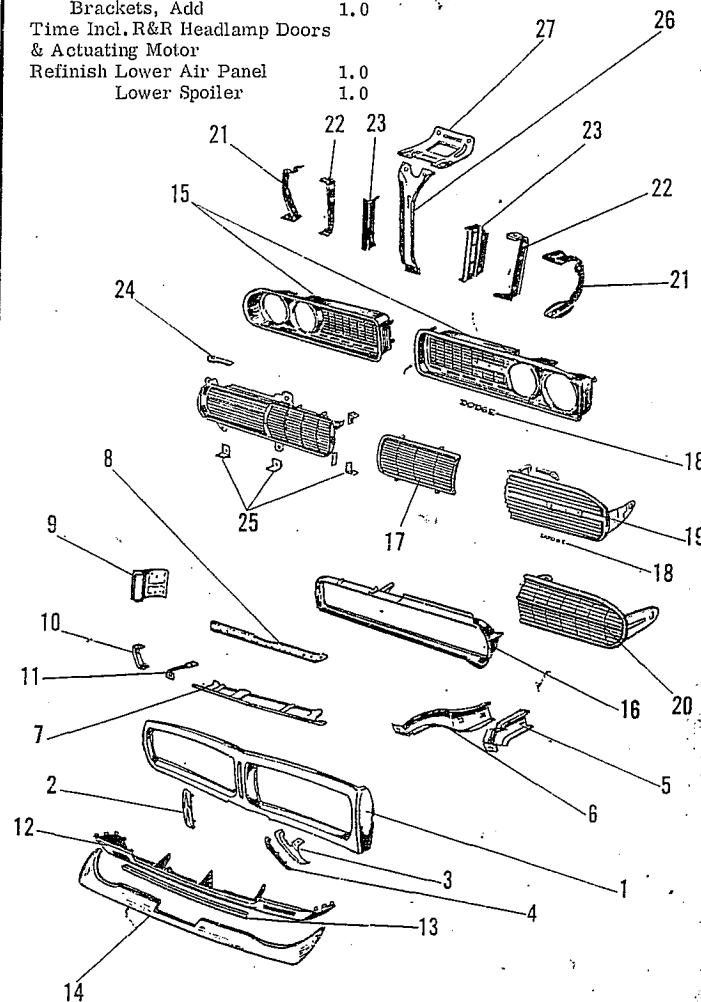
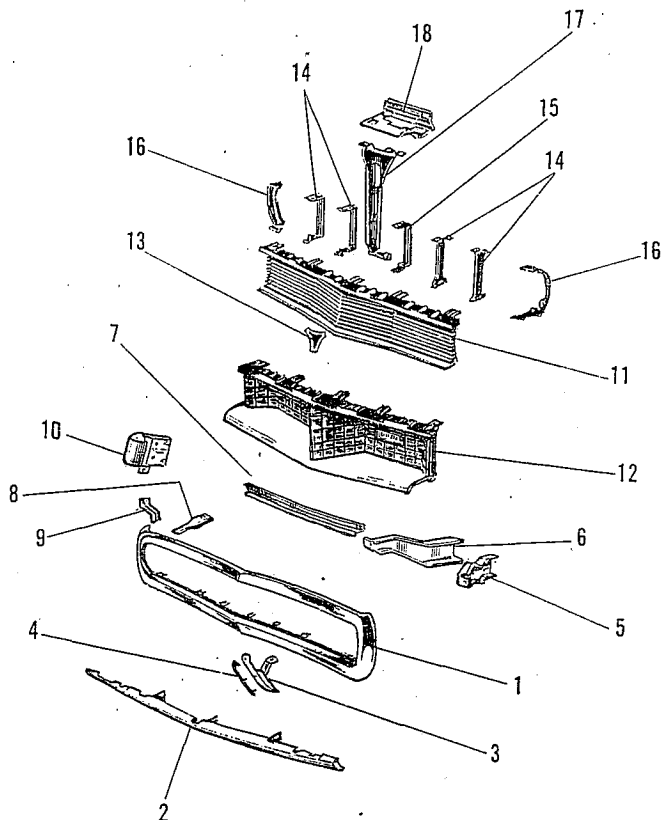

1. Face Bar		3595108	2.3	80.18
2. Shield, Lower Air		3442104	#1.0	26.41
(#Includes R&R Parking Lamps)				
3. Guard, Bar	(2)	3464356		11.45
4. Cushion, Guard	(2)	3464358		2.28
5. Support, Bar Outer		3464310-1		5.67
6. Inner		3464306-7		5.67
7. Brace, Guard		2962292		4.31
8. Bar, Alignment	(2)	3464319		.99
9. Bar, Jacking	(2)	3464316		.99
10. Pad, Bar Impact		3464312-3		4.19
11. Grille	71	3442079	#.7	22.77
12.	72	3573372	#.7	23.66
(#Includes R&R Headlamp Doors)				
13. Ornament, Grille Center	71	3443110	.2	2.32
Nameplate, Grille	71	3443554		2.43
14. Bracket, Side Mtg.	71 (5)	3442094		1.36
	72 (4)	3573474		1.36
15. Center Mtg.	72 (1)	3573480		1.36
16. H/Lamp Bezel to Bmpr.		3573838-9		.94
17. Support, Hood Lock Vert.		3611579	.3	3.66
18. Plate, Vertical Support to Yoke		3611581	.3	3.41

1. Face Bar		3595107	#	80.18	
71 Chrome					
Red	Avocado	Yellow	Blue	Plum	Green
3464379	380	381	382	383	384
72 Chrome To Aug. 1971					
From Aug. 1971					
			3595107		
			3595130		
(# See O/H Times Above)					
2. Medallion, Bar Center		3464348		1.97	
3. Guard, Bar	(2)	3464351	.2	11.45	
4. Cushion, Guard	(2)	3464352		2.16	
5. Support, Bar Outer		3464334-5		5.67	
6. Inner		3464330-1		5.67	
7. Reinforcement, Bar		3464365		6.09	
8. Brace, Guard		3464343		3.86	
9. Pad, Bar Impact		3464336-7		4.19	
10. Brace, Bar Alignment					
To Aug. 1971	71-72	3464362-3		1.36	
From Aug. 1971	72	3595132-3		1.36	
11. Brace, Bar Jacking	71-72	3464340-1		.99	

Cont'd.

Cont'd.

FRONT BUMPER & GRILLE, Cont'd.

CHARGER, Cont'd.

12. Shield, Lower Air	3442315	#1.0	30.46
(#Incl. R&R Parking Lamps, w/Mldg. & Spoiler Add .6)			
13. Mldg., Lower Air Shield	71 3443204		4.05
Panel, Lower Shield (Plastic)	71 2998078		23.12
14. Spoiler, Lower Shield	71 3443180		18.04
Grille			
15. w/Exposed Headlamps			
71 w/Colored Bumper	Rt. 3442378	.5	14.82
	Lt. 3442379	.5	17.12
w/Chrome Bumper	Rt. 3442894	.5	14.82
	Lt. 3442895	.5	17.12
72	3573356-7	.5	13.79
w/Concealed Headlamps			
16. Frame	3442864-5		25.90
17. Texture 71 exc.	3574144-5	.3	11.10
500 & "SE"	3574144-5	.3	11.10
72 All	3574032-3	.3	11.10
18. Nameplate, "Dodge" *			
Grille or H/Lamp Door	71 3443554		2.43
	72** 3573458		2.49
(*Also Illustrated & Listed in Headlamp Section)			
(**w/o Concealed Headlamps)			
Door, Headlamp (w/Texture)*			
w/Concealed Headlamps			
19. 71	Rt. 3574146	.5	12.30
	Lt. 3574147	.5	12.30
20. 72	3574028-9	.5	13.69
(*Also Illustrated & Listed in Headlamp Section)			
Bracket, Grille to Bumper			
w/Exposed Headlamps			
21. Outer	3442310-1		1.79
22. Inter. (2)	71 3442304		1.36
	72 3573459		1.79
23. Inner (2)	71 3442298		1.79
	72 3573461		1.12
w/Concealed Headlamps			
24. Upper Outer	3443284-5		.80
25. Lower & Inner (8)	3443281		.75
26. Support, Hood Lock Vertical	3442323		3.66
27. Plate, Vertical Support to Yoke	3442320		4.05

FRONT LAMPS, Cont'd.

HEADLAMP, Cont'd.
EXPOSED, Cont'd.

Bezel or Door			
4. Coronet	71 3442030-1	.2	9.02
	72 3573248-9	.2	10.02
Charger - See Item 15 in Grille Section.			
5. Shield, Bezel			
Coronet *	71 3442622-3		4.77
	72 3573470-1		4.77
Charger	71 3442618-9		4.77
	72 3573456-7		4.77
(*Not Illustrated)			
6. Adapter, Lamp Mtg.			
Coronet	(2) 3573535		4.58
Charger	(2) 3442358		4.97

CONCEALED

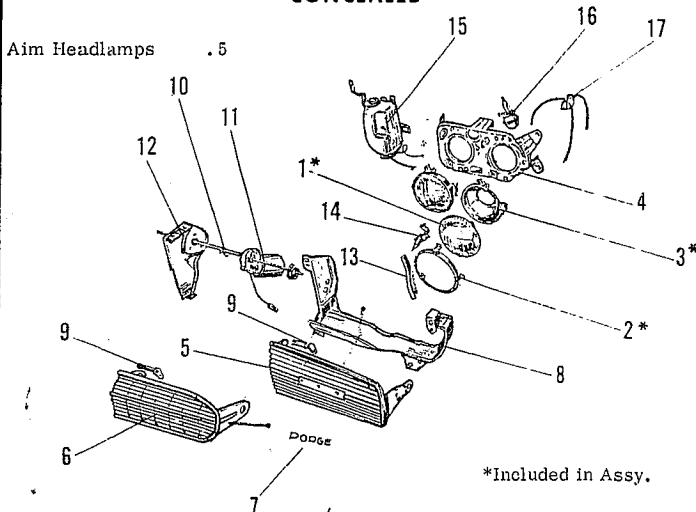

FRONT LAMPS

HEADLAMP
EXPOSED

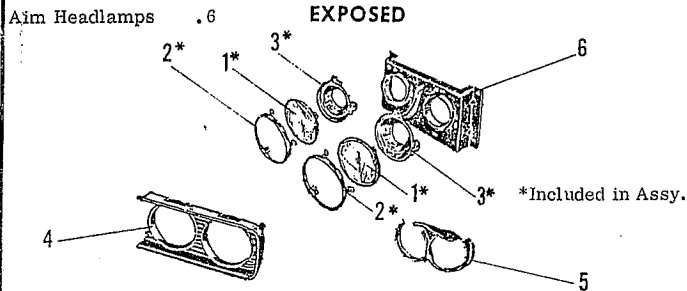

Headlamp Assembly (w/o Door)			
Hi-Lo Beam	Outer	71 3443298-9	# 9.31
		72 3573784-5	# 9.31
Hi Beam	Inner	71 3443302-3	# 9.31
		72 3443176-7	# 9.31
(#Incl. R&R H/Lamp Doors, One .4, Both One Side .5, For Charger Add .5 to R&R Grille)			
1. Sealed Beam			
Hi-Lo Beam	Outer	152286	# 2.89
Hi Beam	Inner	152285	# 2.89
(#One .2, Two .4, Four .5)			
2. Ring, Beam Retaining			
(4) (3 Tab)		2449525	3.13
(4) (5 Tab)		2998682	3.13
3. Seat & Screw, Beam			
Hi-Lo Beam	Outer	3443124-5	3.01
Hi Beam	Inner	3443120-1	3.01

Headlamp Assembly (w/o Door)

Hi-Lo Beam	Outer	3443172-3	# 9.31
Hi Beam	Inner	3443176-7	# 9.31
(#One .3, Both Same Side .5)			
1. Sealed Beam			
Hi-Lo Beam	Outer	152286	# 2.89
Hi Beam	Inner	152285	# 2.89
(#One .2, Two .3, Four .5)			
2. Ring, Beam Retaining	(4)		
(3 Tab)		2449525	3.13
(5 Tab)		2998682	3.13
3. Seat & Screw, Beam			
Hi-Lo Beam	Outer	3443124-5	3.01
Hi Beam	Inner	3443120-1	3.01
4. Adapter, Headlamp Mounting		3443192	4.97
5. Door, Lamp Rotating*	71 Rt.	3574146	.5 12.30
	Lt.	3574147	.5 12.30
6.	72	3574028-9	13.69
7. Nameplate, Door "Dodge"*	71	3443554	2.43
(*Also Listed in Grille Section)			
8. Housing, Headlamp Door		3442870-1	#.8 12.42
(#Incl. R&R Door)			
9. Crank, Headlamp Door		2998890	2.88
10. Ball, Headlamp Door Torsion		2998888	1.83
11. Motor, Door Rotating		3431437	.4 58.76
12. Bracket, Motor Mounting		3442876	1.74
13. Brush, Headlamp Washer*		3431308-9	2.16
Nozzle & Brkt., H/Lamp Washer*		3431316-7	2.93
14. Pivot, H/Lamp Washer *		3431302-3	8.43
15. Reservoir, H/Lamp Washer		3431410	3.59
Cap, Reservoir Filler*		2497500	.24
16. Actuator, Washer Vacuum* (2)		3514449	3.13
17. Valve, Washer Solenoid*		3514450	6.66
Pump, H/Lamp Washer*		2809013	10.65
(*71 Only)			

Cont'd.

Cont'd.

OCTOBER 1, 1974

DODGE

CORONET & CHARGER 1971-72

FRONT LAMPS, Cont'd.

FRONT LAMPS, Cont'd.

PARK & SIGNAL LAMP

CORONET

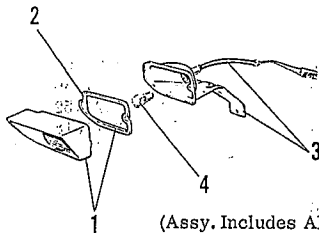

(Assy. Includes All Items Illustrated)

Lamp Assembly	71	3478834-5	.3	8.04
	72	3587484-5	.3	8.04
1. Lens & Gskt. Pkg.		Clear 3420702-3	.2	2.88
		Amber 3420648-9	.2	2.54
2. Gasket, Lens		3403260		.59
3. Housing w/Socket & Cable*				
4. Bulb (1157)		Clear 9417867		.57
		(1157A) Amber 9419780		.82

(*Not Serviced Separately, Use Lamp Assy.)

CHARGER

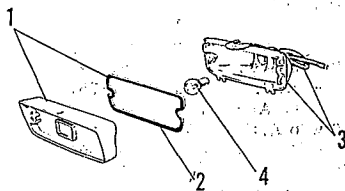

(Assy. Includes All Items Illustrated)

Lamp Assembly	71	3478594-5	.3	8.82
	72	3587476-7	.3	9.81
1. Lens & Gasket Pkg.		3514272-3	.2	3.27
2. Gasket, Lens		3478600		.66
3. Housing w/Cable & Socket *				
4. Bulb Clear (1157)		9417867		.57
		Amber (1157NA) 9423295		1.13

(*Not Serviced Separately, Use Lamp Assy.)

TURN SIGNAL INDICATOR

(ON FENDER)

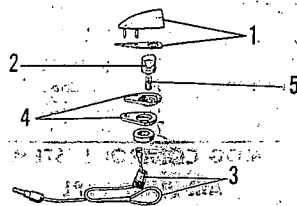

(Assy. Includes All Items Illustrated)

Lamp Assembly (All)	71	2930781	.4	8.38
Coronet	72	3587502	.4	4.58
Charger	72	3587504	.4	4.58
1. Cover & Welt	71*	3479246		1.38
2. Lens *				
3. Socket & Cable	71	2930807		6.68
	72	3588454		2.16
4. Retainer & Gasket*				
5. Bulb (330)		9423277		1.21

(*Not Serviced Separately, Use Lamp Assy.)

Cont'd.

SIDE MARKER LAMP

1971

Assy. Includes All Items Illustrated.

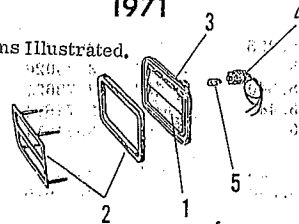

Lamp Assembly				
2 Drs.	(2)	3579152	.3	4.70
4 Drs. exc.	(2)	3621800	.3	6.01
Crestwood S/W	(2)	3621801	.3	6.86
1. Lens *				
2. Bezel & Gasket *				
3. Housing *				
4. Socket exc.		3513686		.99
		S/W N.A.		N.A.
5. Bulb (194)		9421330		.27

(*Not Serviced Separately, Use Lamp Assy.)

1972

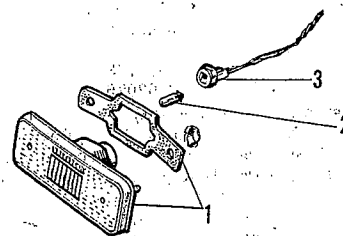

(Assy. Includes All Items Illustrated)

1. Lamp Assembly *		3587436	.3	1.64
		(*Includes Lens, Housing & Gasket)		
2. Bulb (194)		9421330		.27
3. Socket		3513686		.99

COOLING & ENGINE

UNDER HOOD ITEMS

COOLING

- R&R Any Radiator Hose w/Radiator Removed .1
- R&R Fan, Pulley &/or Fan Drive Unit w/Radiator Removed .2
- Pulley Time Includes R&R Fan .2

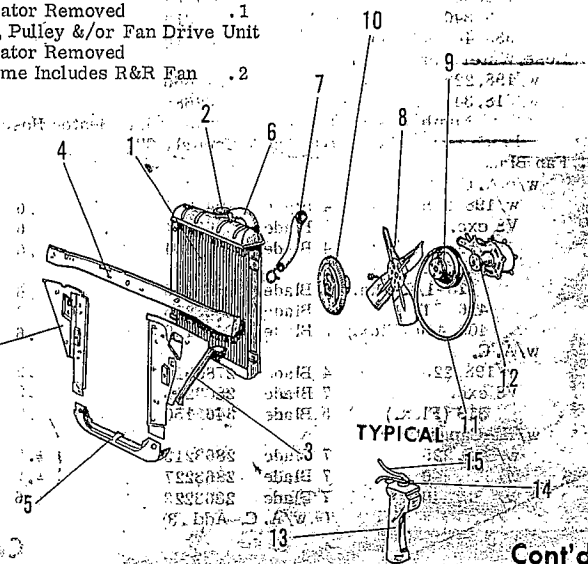

TYPICAL

Cont'd.

COOLING & ENGINE, Cont'd.
UNDER HOOD ITEMS

COOLING, Cont'd.

1. Radiator				
71 w/o A. C.				
w/198, 225	19"	3673908	.9	87.30
w/318	19"	3673026	.9	88.71
w/318, 340	26"	3673027	.9	103.45
w/383, 440	22"	3574614	.9	91.48
w/426	26"	3574611	.9	126.97
w/A. C.				
w/198, 225	22"	3443981	1.1	98.59
w/318, 340	26"	3443970	1.1	126.97
w/383, 440	26"	3574611	1.1	126.97
72 w/o A. C.				
w/225	19"	3673908	.9	87.30
w/318	19"	3673026	.9	88.71
w/340	22"	3673932	.9	(D) 78.27
w/400, 440	22"	3574614	.9	91.48
w/A. C.				
w/225	22"	3574642	1.1	98.59
w/318, 340	26"	3673027	1.1	103.45
w/400, 440	26"	3574611	1.1	126.97
w/Max. Cooling				
w/318	26"	3574624	#.9	126.97
(# w/A. C. Add .2)				
2. Cap, Radiator Filler				
w/o Recovery System		2998982		1.96
w/Recovery System	71	3412851		2.54
	72	3574154		2.54
3. Panel, Radiator Side				
w/19" & 22" Core		3443306-7	#1.3	4.80
w/26" Core		3443310-1	#1.3	5.24
Crossmember, Side Panel				
4. Upper				
		3672723	#1.0	7.40
5. Lower *				
		2962076	#1.7	15.82
(*Also Listed in Frame Section)				
(# Time is w/Necessary Bolted Parts Removed, R&R Both Side Panels & Upper Crossmember 3.0, R&R Both Side Panels & Both-Crossmembers 4.0)				
Shroud, Fan				
w/225 6 Cyl. w/A. C.	22"	2998327	.9	8.77
V8-w/o A. C.	22"	2998328	.9	8.77
w/A. C.	26"	2998326	.9	11.05
6. Hose, Radiator Upper				
w/o A. C.				
w/198, 225		1881804	.5	3.39
w/318, 340 exc.		1881806	.5	4.54
w/340	72	3462118	.5	5.15
w/383, 440	71	3462114	.5	3.58
w/400, 440	72	3462122	.5	3.58
w/426	71	1881810	.5	5.32
w/A. C., w/Max. Cooling				
w/198, 225		1881812	.5	3.71
w/318, 340		3462102	.5	3.58
w/383, 400, 440		2863257	.5	3.65
7. Hose, Radiator Lower				
w/198, 225		2863278	.6	4.00
w/318, 340		1881810	.6	5.32
w/383, 400, 426, 440		3462119	.6	4.40
Hose, Water Pump By-Pass				
w/198, 225 *		1315466	.46	
w/318, 340		3462688	1.68	
(*Part Number is for 50 Ft. Roll of 5/8" I. D. Heater Hose, Price is Per Foot, Use Approximately 3")				
8. Fan Blade				
w/o A. C.				
w/198, 225	4 Blade	1947907	.6	6.60
V8 exc.	7 Blade	2863224	.6	17.71
318	4 Blade	2265034	.6	6.68
340 (72)				
18-1/2" Dia.	7 Blade	2863216	.6	17.71
426 (71)	7 Blade	2863216	.6	17.71
400, 440 (Flex.)	5 Blade	3462150	.6	17.27
w/A. C.				
w/198, 225	4 Blade	2780920	.9	6.68
V8 exc.	7 Blade	2863216	.9	17.71
318 (Flex.)	5 Blade	3462150	.9	17.27
w/Hi-Capacity				
w/198, 225	7 Blade	2863213	#.6	17.71
w/318, 340	7 Blade	2863227	#.6	17.71
w/383, 440	7 Blade	2863223	#.6	19.54
(# w/A. C. Add .3)				

Cont'd.

COOLING & ENGINE, Cont'd.
UNDER HOOD ITEMS

COOLING, Cont'd.

9. Pulley, Fan				
w/o A. C.				
w/198, 225		2202666	#	3.59
w/318, 340		2951836	#	4.19
w/383, 440	71	1821452	#	3.99
w/400, 440	72	3671318	#	3.99
w/426	71	2946716	#	4.45
w/A. C.				
w/198, 225		2406039	#	5.82
w/318, 340		3462825	#	4.19
w/383, 400, 440 exc.		2951092	#	4.19
w/E. C. S.*		3462685	#	5.82
(#Use Fan R&R Time)				
(*E. C. S. Indicates Emission Control System)				
10. Fluid Drive Unit, Fan				
w/o A. C. V8		3462112	.4	32.04
w/A. C. V8 exc.		3462107	.6	34.63
318*		3462108	.6	34.63
383, 400, 440**		2863260	.6	43.63
(*w/2.71, 2.76 & 2.94 Rear Axle)				
(** exc. w/2.71, 2.76 & 2.94 Rear Axle)				
Pulley, Fan Idler				
6 Cyl.		2953165	.3	11.57
V8		2240397	.3	10.20
11. Belt, Fan Drive *				
Engine to Alt. to Fan				
w/198, 225	71	3671682	#	5.62
	72	3671682	#	5.62
w/318, 340 w/o A. C.		3671524	#	4.86
w/A. C.	71	2128751	#	4.92
w/60 Amp. Alt.**		3512522	#	9.32
w/383, 440 w/o A. C.	71	2806216	#	4.80
w/A. C.	71	1551006	#	5.32
w/400, 440 exc.	72	2951898	#	4.74
60 Amp. Alt.	72	3671498	#	10.10
w/426	71	2658895	#	4.68
Engine to Fan				
w/318 37-1/2"		3462911	#	4.10
w/318, 360 37"		3418339	#	4.10
w/383, 400, 440		3462866	#	4.03
(*For Other Belts, See Approp. Section) (**Dual Belt Set)				
(#R&R Any Outside Belt .3, Each Add'l. Belt Add .1)				
12. Water Pump				
w/198, 225		2808679	#1.0	28.85
w/318, 340 w/o A. C.		3420038	1.0	31.50
w/A. C.		3429037	1.5	31.50
w/383, 440 w/o A. C.	71	2808680	.8	28.50
w/A. C.	71	3683834	1.0	28.50
w/400, 440 (All)	72	3683834	1# .8	28.50
w/426	71	3683834	1# .8	28.50
(#w/A. C. Add .5) (1# w/A. C. Add .2)				
Housing, Water Pump				
71 w/383, 426, 440		2951806	(D) 20.72	
72 w/400, 440		3671315		25.37
13. Tank, Coolant Recovery				
	71	3412849		3.59
	72	3574151	.3	5.01
Bracket, Recovery Tank				
	71	3412884		13.72
14. Cap, Recovery Tank				
	72	3574152		.72
15. Tube, Radiator Tank				
	72	3574155		.89

SMOG CONTROL SYSTEM

AIR PUMP TYPE

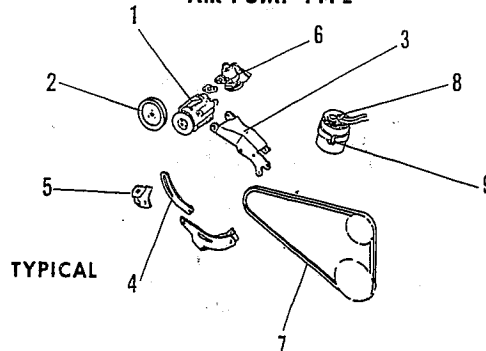

TYPICAL

Cont'd.

OCTOBER 1, 1974

DODGE

CORONET & CHARGER 1971-72

COOLING & ENGINE, Cont'd.
UNDER HOOD ITEMS

COOLING & ENGINE, Cont'd.
UNDER HOOD ITEMS

SMOG CONTROL SYSTEM, Cont'd.

AIR PUMP TYPE

(1972 ONLY)

(6 CYL. & V8 w/400 or 440)

1. Pump, Air	3614985	57.47
2. Pulley, Pump 6 Cyl.	3671309	2.54
V8 w/o A.C.	3671030	2.28
w/A.C.	3614960	2.54
3. Bracket, Pump Mounting 6 Cyl.	3671481	2.37
V8 w/Rt. Mtd. Pump To 2-24-72	3614957	5.55
After 2-24-72	3698646	5.55
V8 w/Lt. Mtd. Pump - Front	3698273	7.07
Rear	3698274	4.68
Support, Pump to Eng. 6 Cyl.	3614996	2.22
4. Strap, Pump Adj. 6 Cyl.	3671478	2.54
V8	3671479	3.27
5. Extension, Adj. Strap	3671477	1.64
6. Valve, Diverter 6 Cyl.	3671044	15.07
V8 w/Rt. Mtd. Pump w/Lt. Mtd. Pump	3671042	15.07
3698698	15.07	
Valve, Pump Check 6 Cyl.	3671038	4.58
V8 w/Rt. Mtd. Pump w/Lt. Mtd. Pump	3671039	4.58
3671038	4.58	
7. Belt, Pump Drive 6 Cyl.	35" 2951958	# 3.97
V8 w/o A.C.	53" 3512050	# 4.98
w/A.C. w/o P.S.	44" 2951202	# 4.59
w/P.S.	59" 3671256	# 5.62
(#R&R Any Outside Belt .3, Each Additional Belt Add .1)		
8. Canister, Fuel Vapor Filter, Canister	3577584	26.20
3577586	.74	
9. Bracket, Canister Mtg. Tube, Air Injection 6 Cyl.	3671704	3.01
V8 w/Rt. Mtd. Pump w/400	3671303	8.94
w/440	3698451	11.10
3698452	11.10	
w/Lt. Mtd. Pump Rt.	3698666	21.91
Lt.	3698662	21.91

ELECTRICAL

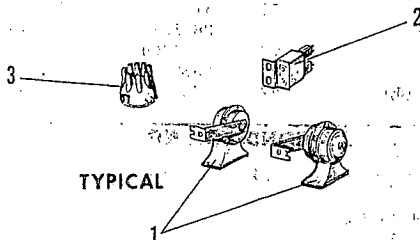

1. Horn Pkg. Hi Note	2808869	10.62
Lo Note	2808868	10.62
3579205		4.44
(*Horn & Key Warning Buzzer w/Relay)		
Horn Ring or Button - See Steering Column		
3. Cap. Distributor 6 Cyl.	2642986	3.81
V8	2444507	4.44
Relay, Starter	2444442	4.15

Cont'd.

ALTERNATOR PARTS

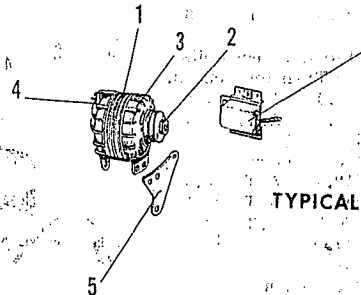

TYPICAL

1. Alternator w/Pulley* 71 exc.	1 Groove	3621853	#.4	84.00
	2 Groove	3621853	#.4	84.00
Alternate 60 Amp.	2 Groove	3621853	#.4	84.00
	1 Groove	3621861	#.4	95.25
2-3/4" Pulley	2 Groove	3621862	#.4	95.25
3" Pulley	2 Groove	3621861	#.4	95.25
72 w/o Smog Control exc.	1 Groove	3621853	#.4	84.00
50 Amp.	2 Groove	3621853	#.4	84.00
60 Amp.	1 Groove	3621867	#.4	95.25
2-3/4" Pulley (a)	2 Groove	3621862	#.4	95.25
(b)	2 Groove	3621865	#.4	95.25
3" Pulley (a)	2 Groove	3621861	#.4	95.25
(b)	2 Groove	3621867	#.4	95.25
72 w/Smog Control exc.	1 Groove	3656218	#.4	84.00
60 Amp.	1 Groove	3656471	#.4	95.25
(*NOTE: For Higher Amp. Leece-Neville Alternator, Contact your Local Dealer For Information)				
(a) Alternator Stamped No. 3438704.				
(b) Alternator Stamped No. 3656451 (# w/A.C. Add .1)				
2. Pulley, Alternator 2-1/2" Dia. exc.	1 Groove	2444478	#.4	3.78
w/Smog Control 1 Groove		3656200	#.4	N.A.
2-3/4" Dia. 2 Groove		2875709	#.4	6.49
3" Dia. exc. 2 Groove		2875711	#.4	4.38
3" Dia.* 2 Groove		2095059	#.4	4.10
(#Includes R&R Alternator)				
(*71 Alternator Stamped No. 3438177)				
3. Shield, Front (D.E.)		2095945	#	9.40
4. Rear (R.E.) 71		3438204	#	7.45
72		3438711	#	26.55
(#R&R One or Both 1.3)				
5. Bracket, Alternator Mounting 6 Cyl.		3671680	#.2	5.55
V8 w/o A.C. w/318,340		2951834	#.2	.98
w/400,440		2951640	#.2	1.80
V8 w/A.C. w/318,340 Front*	To 6-72	3698992	#.2	4.19
	From 6-72	3698992	#.2	4.19
Rear*		2951866	#.2	1.97
w/400,440		2951015	#.2	1.21
(*Also Listed in Air Conditioning Section)				
V8 w/Air Pump* w/400,440 To 2-72		3614957	#.2	5.55
From 2-72		3698646	#.2	5.55
(*Also Listed in Smog Control Section)				
(#w/Alternator Removed)				
6. Regulator, Voltage*		3438150	#.2	17.90
*NOTE: For Higher Amp. Regulator, For Leece-Neville Alternator, Contact Your Local Dealer for Information				
(#Add .5, if necessary to Adjust)				

Cont'd.

COOLING & ENGINE, Cont'd.
UNDER HOOD ITEMS

ENGINE

- R&I Engine Assy.
 - 6 Cyl. S.T. #5.1 A.T. #5.5
 - V8 S.T. #6.0 A.T. #6.6
- Engine R&R
 - Incl. Transfer Elect. & Fuel Units
Does Not Include Transfer Access.
 - 6 Cyl. S.T. #7.1 A.T. #7.5
 - V8 S.T. #8.5 A.T. #9.1
 - Short Block R&R
 - Incl. Grind Valves & Tune
 - 6 Cyl. S.T. #12.7 A.T. #13.7
 - V8 exc. S.T. #17.3 A.T. #18.0
 - 426 S.T. #20.0 A.T. #21.0
 - 440 S.T. #17.6 A.T. #18.6
 - Cylinder Block R&R
 - Incl. Grind Valves & Tune
 - 6 Cyl. S.T. #18.0 A.T. #19.3
 - V8 - Not Available
 - (#w/A.C. Add .5, Does Not Include
Evacuate & Recharge System)
 - Adjust Linkage Complete 1.0
 - Clutch or Disc R&R
 - 3 Speed 2.4
 - 4 Speed exc. 3.2
 - 426 4.2
 - 440 Hi-Perf. 4.6
 - Transmission R&R
 - 3 Speed 1.8
 - 4 Speed exc. 3.4
 - 426 4.3
 - 440 Hi-Perf. 4.7
 - Auto. exc. 3.9
 - 426, 440 Hi-Perf. 4.9

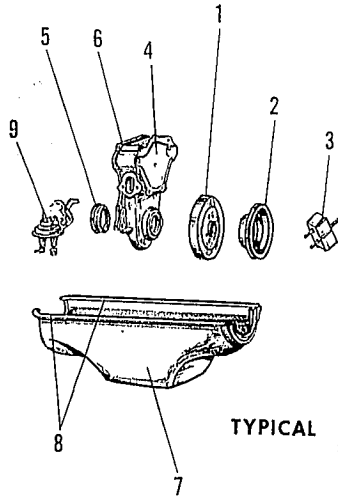

TYPICAL

- 1. Damper, Vibration
 - w/198, 225 2806211 #2.0 23.64
 - w/318, 340 exc. 71 2951673 #.9 24.36
 - 340* 72 3614369 #.9 24.36
 - w/383, 440 exc. 71 3751160 #.9 24.36
 - 383* 71 2658457 #.9 24.36
 - 383* 71 3577180 #.9 24.36
 - 440 Hi-Perf. 71 3512017 #.9 41.94
 - w/426 71 2658871 #.9 44.91
 - w/400, 440 exc. 72 3614371 #.9 24.36
 - 400* 72 3614374 #.9 24.36
 - 440 Hi-Perf. 72 3614372 #.9 39.54
- (*w/Cast Type Crankshaft)
- (# exc. w/Radiator Removed .4, Incl. R&R Pulley)
- 2. Pulley, Crankshaft
 - 6 Cyl. w/P.S. 2205518 #.6 4.19
 - w/A.C. 2202794 #.6 4.19
 - V8 w/o A.C.
 - 71 exc. w/o P.S. 1821449 #.6 3.99
 - w/P.S. 2946789 #.6 5.82
 - w/426 w/P.S. 2946713 #.6 9.54
 - 72 w/318, 340 w/o P.S. 3614375 #.6 3.99
 - w/P.S. 3614378 #.6 5.82
 - w/60 A. Alt. 3614376 #.6 15.11
 - w/400, 440 w/o P.S. 3671319 #.6 3.99
 - w/P.S. 3671320 #.6 5.82
 - w/60 A. Alt.* 3671325 #.6 22.29
 - w/E. C.S. 3671321 #.6 10.72
 - w/60 A. Alt.** 3671323 #.6 6.86
 - V8 w/A.C.
 - 71 w/318, 340 2951122 #.6 12.16
 - w/383, 440 2 Groove 2968252 #.6 5.54
 - 4 Groove 2951122 #.6 12.16
 - 72 w/318, 340 3614377 #.6 10.72
 - w/400, 440 3614382 #.6 12.16
 - (* 3 Groove (** 2 Groove) (# w/Radiator Removed .3)
- 3. Insulator, Engine Front Support
 - All w/198, 225 Rt. 2806476 1.0 5.10
 - Lt. 2658283 1.0 5.25
 - 71 exc. (2) 2536121 1.0 5.80
 - S/W (2) 2863735 1.0 5.80
 - w/426 Rt. 2532708 1.0 5.80
 - Lt. 2951599 1.0 7.30
 - 72 exc. 2863735 1.0 5.80
 - w/340 2536121 1.0 5.80

Cont'd.

COOLING & ENGINE, Cont'd.
UNDER HOOD ITEMS

ENGINE, Cont'd.

- Insulator, Engine Rear Support
 - 6 Cyl. 2533145 .6 6.05
 - V8 exc. 3642831 .6 6.15
 - w/426 3410310 .6 8.10
- Bracket, Front Support Insulator
 - w/198, 225 Rt. 2806479 # 2.69
 - Lt. 2532277 # 2.39
 - w/318, 340 Rt. 3418394 # 2.64
 - (318) Lt. 2806025 # 3.12
 - + (340) Lt. 3418400 # 4.53
 - w/383, 400, 440 Rt. 2536132 # 2.51
 - Lt. 2863751 # 4.71
 - w/426 Rt. 2951601 # 10.59
 - Lt. 2780673 # 10.01
- (# .3 w/Insulator Removed)
- Crossmember, Rear Engine Support
 - Trans. Mtg. 3583188 #.4 13.32
- (#Includes R&R Insulator)
- 4. Cover, Timing Chain Case
 - 6 Cyl. 2863126 #2.3 9.73
 - V8 exc. 3698614 # 11.88
 - w/318, 340 2951671 #3.6 26.88
 - (# w/A.C. Add .5) (# w/383, 400 2.4, w/426 3.9, w/440 2.4 w/A.C. Add .5)
- 5. Seal, Timing Cover Oil
 - 6 Cyl. 2899531 # 2.30
 - V8 exc. 2536481 # 2.50
 - w/318, 340 3751235 # 2.30
- 6. Gasket, Timing Cover Case
 - 6 Cyl. 1947554 # .58
 - V8 exc. 2264794 # 1.10
 - w/318, 340 2129012 # .69
- (#Use Cover Time)
- 7. Pan, Engine Oil
 - 6 Cyl. 3614264 1.6 23.75
 - V8 w/318, 340 3614227 2.3 24.00
 - w/383 71 3671693 2.3 24.00
 - w/400 72 3671693 2.3 24.00
 - w/426, 440 71 3671852 2.3 24.00
- 8. Gasket, Oil Pan
 - 6 Cyl. (Set) 2240647 4.15
 - V8 exc. 2658685 1.50
 - w/318, 340 (Set) 3514157 3.30
- Oil Filter
 - Sealed Can Type (Std.) Long 1851658 .3 4.63
 - Short 3549957 .3 4.63
 - (Hi-Speed) 2536186 .3 4.60
 - Cartridge Type 2532756 .3 9.17
 - Cartridge, Filter 2532752 .3 3.60
- 9. Fuel Pump
 - w/198, 225 71 3420834 .5 14.09
 - 72 2932798 .5 14.26
 - w/318, 340 71 3620795 .7 15.70
 - 72 3744806 .7 14.90
 - w/383, 440 71 3621675 .7 13.05
 - w/400, 440 72 3621609 .7 15.70
 - w/426 71 2585118 .7 13.16
 - w/440 3-2 Bbl. 72 3621610 .7 15.70

AIR CONDITIONING

R&R Does Not Include
Evacuate & Recharge System 1.4
Capacity of System
3 Lb. 2 Oz. to 3 Lb. 6 Oz.
Refrigerant - Freon 12
If all A/C refrigerant has been lost by
collision damage the receiver-dehydrator
should be replaced. Replacement of
collision damaged A/C parts on a system
still pressurized may not require receiver
dehydrator renewal.

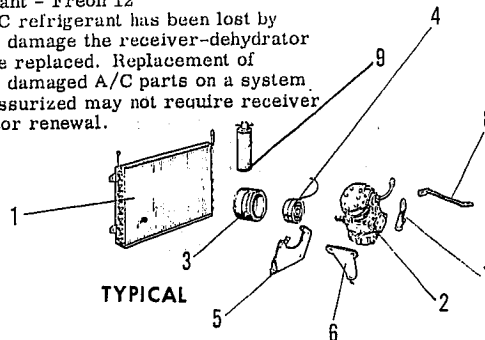

TYPICAL

Cont'd.

OCTOBER 1, 1974

DODGE

CORONET & CHARGER 1971-72

COOLING & ENGINE, Cont'd.
UNDER HOOD ITEMS

AIR CONDITIONING, Cont'd.

1. Condenser 71 6 Cyl.	3441064	.6	(D)89.99
V8	3441065	.6	(D)81.95
72 All	3441934	.6	103.94
2. Compressor w/o Pulley			
V2	71 3609284	.9	127.39
RV2	3609285	.9	127.39
Belt, Comp. Drive			
w/225	3418384	#	6.80
w/318, 340 54-1/4" (Dual)	3462974	#	10.24
w/400, 440 59" (Dual)	2951614	#	10.99
(#R&R Any Outside Belt .3, Each Additional Belt Add .1)			
3. Clutch w/Pulley & Hub			
1 Groove 6-5/8" O.D.	2521824	.6	62.95
2 Groove 5-3/8" O.D. *	2837163	.6	64.90
6-1/4" O.D. **	2936761	.6	64.90
(*Warner Type) (**Pitts Type - 71 Only)			
Bearing, Clutch	1769318	1.0	19.65
4. Coil, Clutch Field			
1-3/8" x 4-13/16"	3502324	.8	31.40
1-7/8" x 4-3/16"	3502746	.8	31.40
Gas Seal Pkg., Comp. Crankshaft	1426501	1.3	6.95
Bracket, Comp. Mtg.			
5. Front			
w/225	71-72 2468809	#	6.01
w/Air Pump	72 3698576	#	6.01
w/318, 340 to 6-72	3698992	#	4.19
From 6-72	3698992	#	4.19
w/383, 440	71 2899526	#	4.19
w/400, 440	72 3513000	#	3.99
6. Rear			
w/318, 340	2951866	#	1.88
w/383, 400	2951809	#	2.61
w/440	2899961	#	2.61
7. Side (Lt.) w/318, 340	3418261	#	1.38
(#R&R w/Compressor Removed)			
8. Support, Comp. Mtg.			
Rt. Side			
w/225	2806152	2.17	
w/318, 340	3751243	2.28	
Rear			
w/225	Rt. 2946134	2.74	
w/383, 400	Lt. 3462354	2.16	
	Lt. 3462022	2.17	
w/440	Rt. 3462353	2.16	
	Lt. 3462023	2.17	
Comp. to Cyl. Head			
w/225	72 3671203	2.28	
Comp. to Engine			
w/225	72 3671104	2.48	
Comp. to Intake Manifold			
w/225	72 3614981	2.28	
9. Receiver Drier *	3502015	.3	21.50
Switch, Low Pressure Cut Out*	3502016	5.19	
(*If Old Drier Stamped 3441736, Both * Items Must Be Used)			
Valves			
Pressure Regulator	3555995	27.13	
Temperature Regulator	2837402	27.13	
Expansion	2932843	1.0	36.65
Motor, Blower	3514305	.8	30.85
Refrigerant (1 Lb. Can)	3837730	1.78	

HEATER PARTS

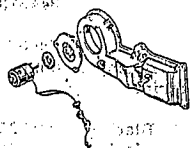

Motor, Blower	3579172	#1.9	23.30
(# exc. 1971 - 2, 6)			
Hose, Heater			
1/2" I.D. *	2936388	.44	
5/8" I.D. *	1315466	.46	
(*Part Number is For 50 Ft. Roll - Price is Per Foot)			
Housing, Heater (Engine Side)			
w/Comb. Htr. & A.C.	3502245	40.28	

HOOD

Refinish Hood			
exc.			2.5
w/2 Tone			3.5
Add to Hood R&R			
to Drill for Nameplate		.2	
to Drill for Each Mldg.		.2	
for Front Tie Down Pins #.6		.8	
(#Incl. Locate & Drill Holes)			
for Stripes or Decals		.8	
Stripe tape or decal time does			
not include removal of old			
tape or decal.			
1. Panel, Hood			
4 Doors	71 3684559	1.0	116.65
	72 3684559	1.0	116.65
2 Doors exc.	71-72 3684033	1.0	114.27
Super B&R/T*	71 3482535	1.8	119.00
Rallye	72 3611212	1.1	114.27
w/Fresh Air Int.	71 3482471	1.8	119.00
(*w/426, 440 Engine)			
Ornament, Hood Top R/T	71 3443617		23.07
Louvre, Hood Top Orna. R/T 71	3443547		36.40
3. Moulding Pkg., Front			
Coronet *	3579557	.2	5.09
Charger **	3620248	.2	5.68
Moulding, Rear *	3443132	.3	5.50
(* 71 Brougham & Crestwood, 72 All)			
(** 71 Charger 500 & SE, 72 All)			
4. Letters, Name (71 4 Drs.)			
"D"	"O"	"G"	"E"
3443365	367	369	371 373
# (One .2; All .3)			
# (ea.)			.92
5. Nameplate, Hood			
Front "Dodge" 72 Charger			
w/Concealed H/Bumps	3443554		2.43
6. Side			
"340 Magnum"	3573632		4.64
"383 Magnum"	3443627		4.64
"400 Magnum"	3574059		4.64
"440 Magnum"	3443516		4.64
"440 Six Pack"	2998804		5.17
7. Decal, Top			
Front "R/T" (Letters)	71 3443057	.3	3.59
Fresh Air Door			
"Ram Charger"	3443636-7	.3	1.43
8. Tape & Decal (71)			
Super Bee w/o Fresh Air	3573736	.8	30.14
w/Fresh Air	3573752	.8	30.14
9. Tape, Center Stripe			
R/T w/o Fresh Air	3573751	.8	27.64
w/Fresh Air	3573755	.8	27.64
Tape, Hood Stripe			
Front Flange	72 3573958		1.25
Rear	3573770		16.81
Stud & Rin Pkg., Hood Tie Down			
2 Drs. (Front Corners)	3685951		13.28
10. Hinge, Hood	3582936-7	#.4	7.77
(#exc. w/Hood Removed .2)			

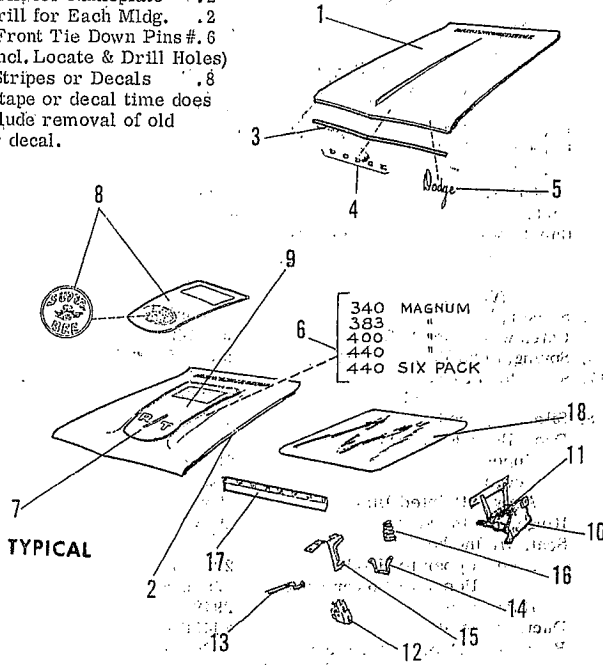

340 MAGNUM
383
400
440
440 SIX PACK

TYPICAL

Cont'd.

HOOD, Cont'd.

FRONT FENDER, Cont'd.

11. Spring, Hinge					
2 Dr. exc.	3586092	.2	2.43		
Sport & Fresh Air	3586094	.2	2.43		
4 Drs.	3586093	.2	2.43		
12. Lock or Latch					
2 Drs. w/o Panel Release	3695872	.3	6.08		
w/Panel Release	3695886	.3	6.08		
4 Drs.	3695860	.3	5.75		
Lever, Latch Release	71 6586037	(D)	.83		
13. Handle, Lock Release					
2 Drs.	3508330		1.64		
4 Drs.	3508335		1.64		
Link, Lock Release	2 Drs. 3508332		.79		
Handle & Cable Assy., Lock Rel.					
71	3586984	.5	8.17		
72 (Horiz.)	3586984	.5	8.17		
(Vert.)	3695565	.5	8.17		
14. Striker, Lock	2486697	.2	.59		
15. Catch w/Handle, Safety	2999149	.2	2.68		
16. Spring, Hood Release Pop-Up	2935375		.24		
17. Seal, Hood to Yoke	3442118	.2	2.37		
to Cowl	3440865	.3	2.61		
18. Silencer, Hood	3443230	.3	5.82		
Door, Hood Fresh Air Intake *					
Upper	2949449		19.54		
Lower	3508177		12.57		
Assy. (Painted Black)	2949449		19.54		
Hinge, Air Intake *	2948468		N.A.		
Seal, Air Intake *					
Door Upper to Hood	2998652		.99		
Upper to Lower Door	2998654-5		.53		
Duct Lower	2949233		17.58		
Duct, Air Intake *	3442614		15.11		
Reservoir, Door Vac. Actuator *	3420851		4.15		

(*Fresh (Cold) Air Intake System)

4. Shield, Headlamp Splash					
2 Drs.	3442390-1				4.30
4 Drs.	3442392-3				3.06
5. Shield, Fender to Dash					
2 Drs.	3439424-5	.5			6.60
4 Drs.	3439422-3	.5			6.60
6. Shield, Side Rail Lower Splash Lt.	3404435				3.55
7. Shield, Front Susp. X-Mbr.	3642974-5				2.49
8. Brace, Shield Panel to Cowl	2925340-1				3.47
9. Fender to Dash	71 3443544-5				1.11
	72 3573646-7				1.11
10. Brace, H/Lamp Panel to Yoke					
2 Drs.	(2) 3442292				.92
4 Drs.	(2) 3442148				.92
11. Seal, Fender H/Lamp Panel					
2 Drs.	3442364				.92
4 Drs.	3442152				.92
12. Tray, Battery	2925322				3.59
13. Brace, Battery Tray	2530992				.53
14. Shield, Battery Heat *	3404440				4.36
	(* w/70 Amp. Battery)				
15. Strap, Battery Holddown	71 3404404				2.15
	72 3583020				2.15
16. Stud, Holddown Strap					
Outer	2534814				.39
Inner	2074089				.39
Antenna, Radio (60")	3513033	.4			7.31
Mast, Antenna	31" 3513745				4.25
	60" 2889919	(D)			3.42
	76-1/2" 2889934				6.54

MOULDINGS & TRIM

(Pkgs. Include Attaching Parts)

2 DOOR

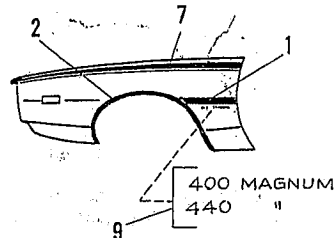
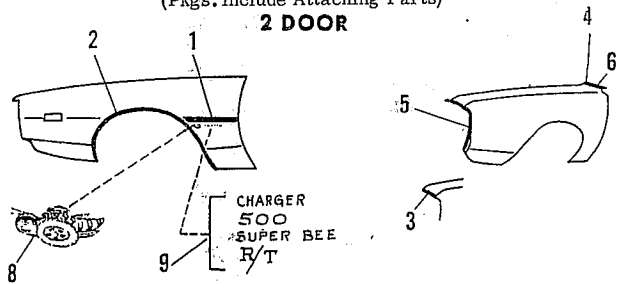

FRONT FENDER

Refinish Fender					2.5
Inner Side Shield R&R					
is w/Fender Removed					
Add to Fender R&R					
for Antenna					.4
to Drill for & Install					
one Mldg.					.3
Ea. add'l. Mldg.					.2
Nameplate					.2
to Drill for Turn Indicator Lamp					.2
for Stripes					.4
Overlay or stripe tape time does not include removal of old overlay or tape.					
1. Fender	2 Drs.	71 3579684-5	#2.2	91.30	
		72 3621774-5	#2.2	91.30	
	4 Drs.	71 3379686-7	#2.2	91.30	
		72 3621776-7	#2.2	91.30	
		(#See Note Above for Additional Time)			
2. Filler, Fender to Bumper	71	2998698-9		2.68	
3. Panel, Fender Shield					
Rt. To 6-72		3642966	#3.0	15.00	
From 6-72		3642966	#3.0	15.00	
Lt.		3642333	#3.0	15.00	

Cont'd.

1. Moulding, Side Black					
To 8-1-71	71-72	3613472-3	.3		2.06
After 8-1-71	72	3680668	.3		2.06
2. Mldg. Pkg., Wheel Opening		3504734-5	.3		4.29
Moulding, Top (Hood Mldg. Extension)					
3. Front		3443210-1	1.2		2.01
4. Rear		3443134-5	1.2		2.26
5. Moulding Pkg., Front (Bumper Outline)		3443208-9	#.2		8.10
		(#w/Bumper Removed)			
6. Tape Pkg., Top Rear Stripe*					
71 Super Bee, R/T					
w/o Door Mirror	Black	3685200-1	#.4		22.55
w/Door Mirror	Black	3685202-3	#.4		22.37
7. Tape Pkg., Side Stripe*					
72	Blue	3685304-5	#.6		18.04
	Green				
	White				
	Black				
	Gold				
	3685306-7	308-9 310-1 312-3	#.6		18.04

(*Pkg. Incl. Door & Quarter for One Side) (#Time is for Fender Only)

(NOTE: Check Local Dealer for Availability of Separate (Fender Only) Tapes.

Cont'd.

OCTOBER 1, 1974

DODGE

CORONET & CHARGER 1971-72

FRONT FENDER

MOULDINGS & TRIM, Cont'd.

2 DOOR

8. Decal, Side "Bee"	71	3569496-7		1.50
9. Nameplate, Side "Charger"	71	3504807	.2	2.28
"500"	72	3680687	.2	2.54
"Super Bee"	71	3504810	.2	1.64
"R/T"	71	3504804	.2	3.73
"400 Magnum"	71	3504809	.2	2.68
"440 Magnum"	72	3680297	.2	4.64
"440 Magnum"	72	3613512	.2	2.43
Medallion, Side Pentastar		2785540		1.04
Charger Emblem		3506410		2.04

4 DOOR

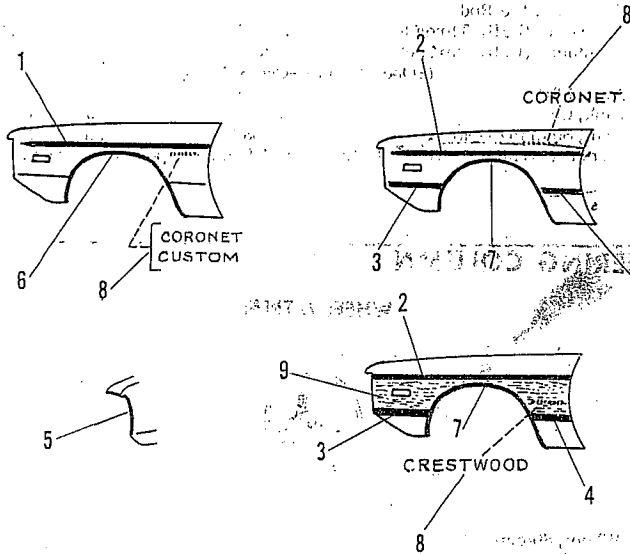

1. Moulding Pkg., Side				
71 Coronet Station Wagon Plain To 1-1-71	3579364-5	.3	5.29	
From 1-1-71	3621540-1	.3	6.16	
71 Coronet Custom Painted To 1-1-71	3579368-9	.3	6.41	
From 1-1-71	3621538-9	.3	6.41	
71 All exc. Crestwood Station Wagon w/Insert				
Black	3620486-7	.3	11.33	
* 3579366-7	3620486-7	.3	11.33	
** 3621536-7	532-3	.3	8.90	
72 Coronet	3621536-7	.3	8.90	
Coronet Custom	3683794-5	.3	10.27	
Plain	3685500-1	.3	6.41	
(* To 1-1-71) (** From 1-1-71)				
2. Moulding Pkg., Side Upper				
Brougham & Crestwood S/W	3579376-7	.2	5.67	
Moulding Pkg., Side Lower				
Brougham & Crestwood S/W				
3. Front	3579370-1	.3	2.79	
4. Rear	3579374-5	.3	2.49	
5. Moulding Pkg., Front (Bumper Outline)				
Brougham & Crestwood S/W (#w/Bumper Removed)	3443178-9	.2	8.68	
Moulding Pkg., Wheel Opening exc.	3504728-9	.2	4.00	
Brougham & Crestwood S/W	3504694-5	.2	4.43	
8. Nameplate, Side "Coronet"	3504801	.2	2.74	
"Custom"	3505432	.2	2.61	
"Crestwood"	3570365	.2	4.19	
9. Overlay, Wood Grain Crestwood Station Wagon (#1.5w/Mtdgs. Removed & After Painting)	3680107	.2	23.33	

FRONT SUSPENSION

Check and Adjust Caster, Camber, Toe-In 1.5
 Toe-In Only .5
 O/H One Side #3.5, Both Sides #5.5
 #w/Disc Brakes Add to Each Side .3
 R&R Does Not Include Alignment
 O/H Includes Alignment

TYPICAL

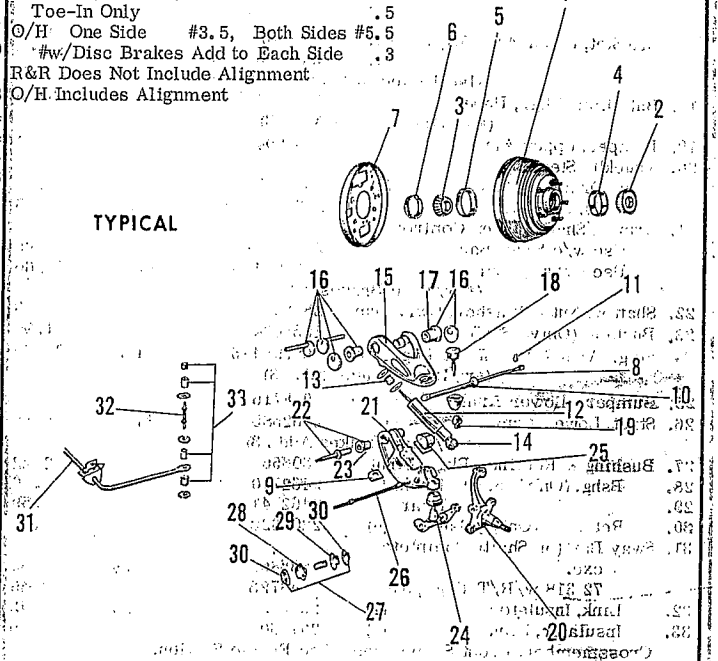

1. Hub & Drum 10" x 2-1/2"	71	3580704	.7	37.86
11 x 3"	72	3580704	.7	37.86
		3580692	.7	46.33
Hub w/Disc (Disc Brakes)		3580506	.9	45.79
2. Cone, Wheel Bearing Outer		1619703	#	2.08
3. Inner		1619701	#	2.73
4. Cup, Wheel Bearing Outer		1619702	#	1.05
5. Inner		1619700	#	1.23
6. Oil Seal, Front Wheel exc.		2808269	#	2.15
w/10" Brakes		2808267	#	1.90
(#R&R Bearings, Cups or Seals .7, exc. w/Disc Brakes .9)				
7. Support (Backing Plate), Brake w/10" Brakes		3461536	1.4	11.45
w/11" Brakes		3461538	1.4	12.02
Splash Shield, Disc Brake		2944710-1	1.1	2.54
Housing w/Shoes, Disc Brake		3744480-1		50.48
Hose, Brake w/Drum Brakes		3461730	#	3.86
w/Disc Brakes		2925163	#	3.86
(#One .6, Both .9 Includes Bleed Brakes)				
8. Torsion Bar Standard				
6 Cyl. exc.		1857774-5		17.60
71 2 Dr.		1857778-9		17.60
V8 exc.		1857776-7		17.60
71 Super Bee		1857778-9		17.60
71 w/426, 440		1857780-1		17.60
Heavy Duty exc.		1857778-9		17.60
71 w/426, 440		1857780-1		17.60
9. Bolt & Swivel Pkg., Bar Adj.		2275468		2.74
10. Seal, Bar Rear Anchor		2071173		1.52
11. Lock, Bar Rear Anchor		1671446		1.13
12. Shock Absorber w/Bshgs. (All)		3683992		14.90
13. Bushing, Shock Upper		2206923		1.52
14. Lower		1635588		1.74
15. Arm (Only), Upper Control		1857856-7		8.57
16. Cam & Bshg. Pkg., Inner (#w/Disc Brakes Add .3)		2084920		8.33
17. Bushing (Only), Inner		2071204		2.60

Cont'd.

FRONT SUSPENSION, Cont'd.

Bracket, Upper Arm Mtg.* Rt.	2467982	14.32	
Lt.	2204185	14.32	
(*Also Listed in Frame Section)			
18. Ball Joint Pkg., Upper	2298534	#1.2	13.35
(# w/Disc Brakes Add .3)			
19. Bumper, Upper Arm	2535204	.4	.72
20. Knuckle, Steering			
w/Drum Brakes	(2) 2535697	1.3	48.85
w/Disc Brakes	2535694-5	1.6	48.85
21. Arm w/Shaft, Lower Control			
Use w/o Sway Bar	2535878-9	#1.7	26.60
Use w/Sway Bar	2535974-5	#1.7	26.60
(# w/Disc Brakes Add .3)			
22. Shaft w/Nut & Washer, Lwr. Arm	2808579		5.98
23. Bushing (Only), Shaft	1858024		1.96
24. Strg. Arm & Ball Joint Pkg., Lwr.	3683984-5	#1.3	23.30
(#w/Disc Brakes Add .3)			
25. Bumper, Lower Arm	2948716		.97
26. Strut, Lower Arm	2462585	#1.7	9.86
(# w/Disc Brakes Add .3)			
27. Bushing & Retainer Pkg., Strut	2808664		2.22
28. Bshg. (Only), Strut Front	2462740		.66
29. Rear	2462741		.59
30. Retainer (Only), Bshg. (4)	2207322		.39
31. Sway Bar (or Shaft) Complete			
exc.	2835862	.8	22.03
72 3/8 w/R/T Pkg., 340	2948723	.8	23.46
32. Link, Insulator (2)	2535992	.5	1.43
33. Insulator, Link (8)	2071604		.39
Crossmember, Front Suspension - See Frame Section.			

STEERING LINKAGE

R&R Does Not Include Align

Adjust Toe-In .5

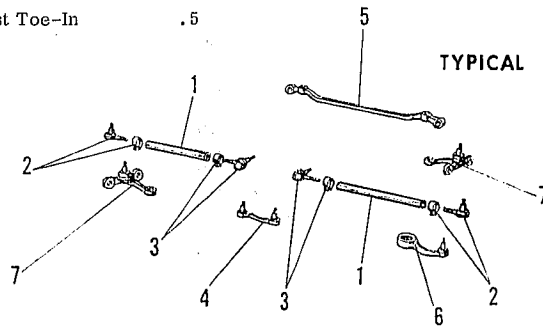

1. Tube, Tie Rod	2072437		2.10
End Pkg., Tie Rod			
2. Outer (R.H. Thread)	3420154	#	8.05
3. Inner (L.H. Thread)	3420155	#	8.05
(#One .3, Two-One Side .5)			
4. Arm, Idler	2535886	.8	12.65
5. Link, Center	2835877	.9	12.23
6. Arm, Steering Gear	2835880	.5	12.02
7. Steering Arm w/Lower Ball Joint - See Front Suspension Section.			

WHEEL

Refinish Wheel .5

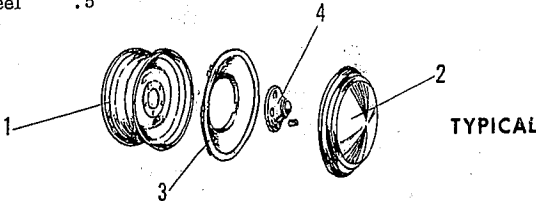

1. Wheel			
14 x 5.00	3621952	.3	16.75
14 x 5.50			
Standard	3621953	.3	17.10
Styled, Class I	3580058	.3	25.10
Styled, Class II	3580059	.3	45.60
14 x 6.00	3420978	.3	18.59
14 x 6.00			
Styled, Class II	3580065	.3	45.60
15 x 6.00			
Heavy Duty	3580063	.3	23.38
15 x 7.00			
Standard	3580070	.3	21.64
Styled, Class I	3580071	.3	28.00
Cap, Wheel Hub	2944089	.3	7.65
2. Cover, Wheel			
Standard (Dodge Division)	71 2944435		17.20
	72 3461460		13.17
Deluxe (6 Spoke)	71 2944441		17.20
Wire	3461467		46.08
3. Ring, Wheel Trim			
Class I, II Wheel	2944424		12.57
Brushed Chrome	3461222		12.57
Dome, Wheel (Class II)	2823842		4.60
4. Applique, Wheel Center			
Class I	71 3461352		8.11
	72 3461458		8.11

STEERING COLUMN

WHEEL & TRIM



Wheel, Steering *			
w/Horn Button			
(Tan)	71 4054GT6	.5	31.10
(Black)	72 4054GX9	.5	31.10
w/Spoke Button			
(Tan)	71 4025GT6	.5	31.10
(Black)	72 4025CX9	.5	31.10
w/Rim Switch			
(Std. Steering)	71 4020FTX	.5	34.38
	72 N.A.	.5	N.A.
(Tilt Steering) (Tan)	71 4012GT6	.5	37.12
(Black)	72 4012FX9	.5	37.12
w/Soft Rim	71-72 4039FX9	.5	37.12
w/Wood Grain	71 4016FTT	.5	47.26
	72 N.A.	.5	N.A.
w/3 Spoke & Partial Pad	72 4008FX9	.5	28.71
Cap or Button *			
Center Type (Tan)	71 4055GT6		2.49
(Black)	72 P100JX9		2.49
Spoke Type	71 N.A.		N.A.
	72 3575564		1.64
Switch, Rim Horn			
w/Std. Steering	71 3467180		5.73
	72 N.A.		N.A.
w/Tilt Steering	71-72 3467181		5.73
Pad or Cover, Wheel Center (Black) *			
w/Spoke Buttons	71 3621461		2.04
	72 3621461		2.04
w/Rim Switch	71 4006GX9		10.65
	72 4011FX9		8.10
w/Soft Rim	71 4005FX9		16.94
	72 N.A.		N.A.
w/Tilt Wheel (Tan)	71 4013GT7		16.13
(Black)	72 4013FX9		15.82
Switch Pkg., Spoke Horn Button	3575954		5.73
Pad & Ring, Wheel Horn			
w/Full or Partial Ring	72 4042FX9		12.86
(*For Colors Not Listed, Call Local Dealer)			

Cont'd.

OCTOBER 1, 1974

DODGE

CORONET & CHARGER 1971-72

STEERING COLUMN, Cont'd.

STEERING COLUMN, Cont'd.

WHEEL & TRIM, Cont'd.

Cover, Wheel Spoke #				
w/Horn Button (Tan)	71	4037GT6	15.50	
(Black)	72	4037GX9	15.50	
Extension, Wheel Hub				
w/Wood Grain Wheel		2996788	.94	
Medallion, Wheel				
w/Horn Button				
w/o Tilt Wheel	71	3467486	1.76	
w/Tilt Wheel	71	2996889	2.22	
Cover, Wheel Hub				
w/Tilt Wheel		2996862	6.86	

(*For Colors Not Listed, Call Local Dealer)

COLUMN - TILT WHEEL

Column Assy.	R&R	#O/H	
w/Column Shift	2.2	3.4	
w/Floor Shift	1.8	2.7	

(#Includes R&I Assy.)

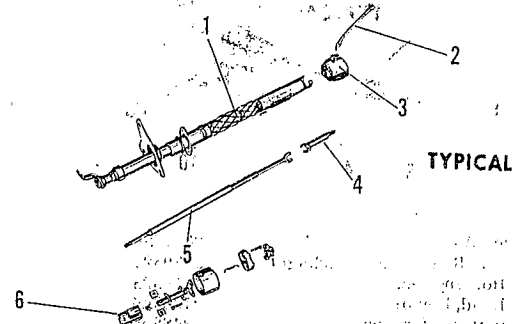

DIRECTIONAL SIGNAL & PARTS

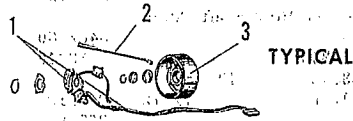

1. Switch, Turn Signal				
w/o Tilt Wheel		3488805	1.6	13.20
w/Tilt Wheel		3575920	1.3	12.05
2. Lever & Knob, Signal Switch				
w/o Speed Control				
w/o Tilt Wheel	71	2947963	2.43	
	72	2947950	2.43	
w/Tilt Wheel		2947952	2.43	
w/Speed Control				
w/o Tilt Wheel	71	3488538	36.08	
w/Tilt Wheel	71	3488540	36.08	
3. Housing, Column Shaft Brg.				
w/o Tilt Wheel				
exc.		3575231	5.04	
Auto. Trans. Col. Shift	71	3575234	5.04	
	72	3575572	5.04	
w/Tilt Wheel		3575221	79.94	

1. Jacket, Steering Column (w/Shift Tube)				
w/Column Shift		3575745		86.35
w/Floor Shift		N.A.		N.A.
2. Lever & Knob, Column Gearshift				
w/Auto. Trans.	71	3575036		6.93
	72	3575216		6.93
3. Housing, Column Upper				
Lever, Column Release		3575221		79.94
Shaft, Steering (w/Power Steering)		3575002		1.50
4. Upper		3467817		13.59
5. Lower		3575217		43.86
Repair Kit, Steering Shaft		3514996		7.23
6. Body, Shaft Coupling				
w/Power Strg.		3579522		6.73

COLUMN - STANDARD

Column Assy.	R&R	#O/H
w/Column Shift	2.1	3.1
w/Floor Shift	1.6	2.5

(#Includes R&I Assy.)

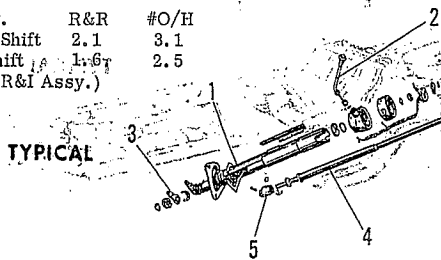

1. Jacket, Steering Column				
exc.		3575261		28.25
3 Speed Manual Trans.				
w/Column Shift		3467190		28.25
2. Lever & Knob, Column Gearshift				
w/3 Speed Manual Trans.		3575215		6.93
w/Auto. Trans.		3575036		6.93
3. Tube, Column Gearshift				
exc.		3467192		17.27
3 Speed Manual Trans.		2996085		17.27
4. Shaft, Steering				
w/Standard Steering		3575540		18.82
w/Power Steering		3575542		18.82
Repair Kit, Strg. Shaft		3514996		7.23
5. Body, Shaft Coupling				
w/Standard Steering		3579521		6.73
w/Power Steering		3579522		6.73

STEERING GEAR

GEAR - MANUAL

Gear Assy.	Adjust	R&R	#O/H
6 Cyl.	.8	1.1	2.6
V8 exc.	.8	1.3	3.0
V8 w/426	.8	1.6	3.2

(#Includes R&I Gear Assembly)

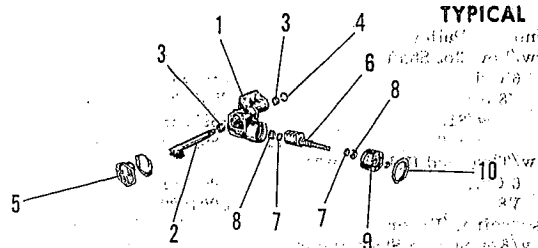

Chuck Assy. (Strg. Gear Assy.)	2537726	76.08
Kit, Strg. Gear Repair	2808420	9.59
(*Bearings, Cups, Seals, Gasket & Shims)		
1. Housing, Gear	2948812	37.84
2. Shaft & Tooth (Cross Shaft)	2127104	21.50
3. Bushing or Brg., Cross Shaft	2948801	1.70
4. Seal, Cross Shaft	2127154	1.39
5. Cover, Cross Shaft	2267152	10.65
6. Worm w/Ball Nut Assy.	2267454	37.07
7. Cone, Worm Bearing (2)	2072060	.76
8. Cup, Worm Bearing (2)	2127097	1.08
9. Adjuster, Worm Bearing	2127146	7.92
10. Nut, Worm Adjusting	2267192	.66

Cont'd.

Cont'd.

STEERING GEAR, Cont'd.

GEAR - POWER

Gear Assy. Adjust R&R #O/H
Power Strg. .6 2.2 5.0
(#Includes R&I Gear Assy.)

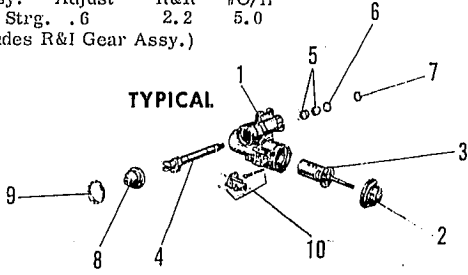

Chuck Assy. (Strg. Gear Assy.)	2537736	223.68
"O" Ring & Seal Package	3579524	12.14
1. Housing, Gear	3579525	52.29
2. Head, Housing	2126946	12.02
3. Worm w/Piston	2948855	41.97
4. Shaft & Tooth (Cross Shaft)	2537775	23.46
5. Bearing, Cross Shaft	2948801	1.70
6. Seal, Cross Shaft	2537154	2.20
7. Seal, Housing Dust	2267351	.59
8. Cover, Cross Shaft	71 3579510	9.81
	72 2948989	8.62
9. Nut, Cross Shaft Cover	1733627	2.16
10. Valve, Gear	3643027	21.24

PUMP - POWER

R&R Pump Assy. 1.5
O/H Includes R&R 1.9

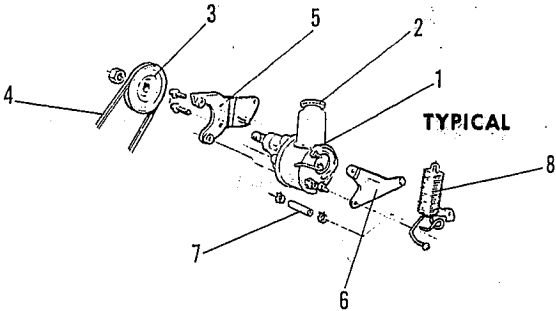

Pump w/o Pulley w/Key Slot Shaft*		
6 Cyl.	2891315	88.77
V8 exc.	2891196	88.77
w/318	2891218	88.77
w/340	71 2891218	88.77
w/Threaded Hole Shaft**		
6 Cyl.	3004801	92.10
V8	3004800	92.96
1. Reservoir w/Filler w/Key Slotted Shaft Pump*		
exc.	2537836	.8 12.23
w/225, 318, 340	2891224	.8 12.74
w/Threaded Hole Shaft Pump**	2891156	.8 5.86
(*w/Oval Filler Tube) (**w/Round Filler Tube)		
2. Cap, Reservoir Filler		
w/Key Slotted Shaft Pump	2891284	2.88
w/Threaded Hole Shaft Pump	2267694	1.43
3. Pulley, Pump		
w/Key Slotted Shaft Pump		
6 Cyl.	3418950	.5 4.84
w/318, 340	2951989	.6 5.08
w/383, 400, 440	2951203	.6 4.84
w/Threaded Hole Shaft Pump		
6 Cyl.	2951157	.6 4.45
w/318, 340	2951901	.6 4.84
w/426 (71)	2951207	.6 10.03

Cont'd.

STEERING GEAR, Cont'd.

PUMP - POWER, Cont'd.

4. Belt, Pump Drive				
6 Cyl.	40-3/4"	3512025	#	4.27
w/318, 340				
w/o A. C.	42-1/2"	2951984	#	4.10
w/A. C.	45-1/2"	2951989	#	5.08
w/383, 400, 440				
exc.	42-1/2"	3419000	#	4.47
440 w/A. C., w/E. C. S.		2843221	#	4.68
w/426	71 39-3/8"	2268386	#	4.68
(#R&R Any Outside Belt .3, Each Additional Belt Add .1)				
5. Bracket, Pump Mtg. (on Pump)				
w/Key Slotted Shaft Pump				
w/225				
Front		3671101	#	2.49
Rear		3671102	#	2.16
w/318, 340				
Front		2951985	#	3.66
Rear		2951987	#	2.49
w/383, 400, 440				
Early Type	Front 71-72	3671889	#	2.49
Late Type	Front 72	3671889	#	2.49
All	Rear	2951198	#	1.88
w/Threaded Hole Shaft Pump				
w/225				
w/318, 340		3462860	#	2.16
w/383, 400, 426, 440		3418348	#	3.66
Early Type	71-72	2951126	#	2.49
Late Type	72	3671887	#	2.49
6. Bracket, Pump Mtg. (On Engine)				
6 Cyl.				
	71	3462417	#	2.16
	72	3671308	#	2.16
w/318, 340				
Front		2951747	#	1.43
Rear		2951852	#	1.97
(#.3 w/Pump Removed)				
Hose, Pump Pressure				
w/Key Slotted Pump Shaft				
6 Cyl. To 2-72		2891345	.3	11.66
From 2-72		2891345	.3	11.66
V8 w/318, 340		2891208	.3	11.66
w/383, 400, 440		2891078	.3	11.34
w/Threaded Hole Shaft Pump				
6 Cyl.				
To 4-72	71	3514988	.3	11.66
From 2-72	72	2891322	.3	11.66
From 4-72	72	2891344	.3	11.66
V8 w/318, 340		3420194	.3	11.66
w/426		3004834	.3	11.13
Hose, Pump Return*		2537699	.2	1.33
7. Hose, Reservoir to Cooler*		2537699		1.33
(*Part Number is for 14" of 5/16" Hose, Use as Required)				
8. Cooler, Pump Oil (V8)				
w/318, 340		2891241		6.86
w/383, 400, 440		2891162		6.86

FRAME

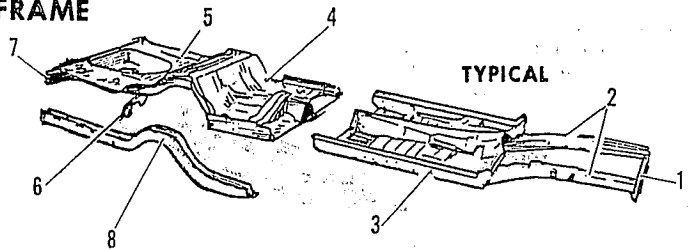

1. Crossmember, Front	2962076	#1.7	15.82
(#w/Bolted Parts Removed)			
Crossmember, Front Suspension (Complete)			
6 Cyl.	3583099	#5.0	77.93
V8	3726799	#5.0	87.86
(#Includes Transfer All Assys., But Not O/H Assys. or Align Wheels. Add to O/H One Knee 2.5, Both Knees 4.5)			
Crossmember, Torsion Bar Anchor w/Anchors	3482523		43.38
Brace, Front Crossmember To Front Susp. X-Mbr.	2962003		2.04
2. Rail, Front Side (Complete)	3482512-3	#7.5	65.88
(#Time is w/Fender & Side Shield Removed)			

Cont'd.

OCTOBER 1, 1974

DODGE

CORONET & CHARGER 1971-72

FRAME, Cont'd.

Reinf., Side Rail to Sill exc. Station Wagon	71- 72	3446242-3 3615158-9		5.43 5.43
Crossmember, Engine Rear Support*		3583188	#.4	13.32
(*Also Listed in Engine Section) (#Incl. R&R Insulator)				
3. Pan, Front Floor		3570438		45.95
4. Pan, Center Floor exc.		3445001		47.07
Station Wagon		3440824		47.07
Extension, Center Floor Pan Front				
2 Drs.	71	3445492-3		11.82
	72	3615692-3		11.82
4 Drs.		3615690-1		13.07
5. Pan, Rear Floor 2 Drs.		3446763	#	48.31
4 Dr.		3445020	#	51.30
Station Wagon		3440566		55.17
(#R&R w/One Qtr. & Back Panel Removed 8.0 w/Both Qtrs. & Back Panel Rem. 7.0)				
Panel, Rear Floor Pan Station Wagon Upper Rt.		3440894		9.09
Lt.		3499877		16.60
Filler		3440794		10.86
6. Crossmember, Rear Floor Pan Rear Shock Absorber		3445023		17.71
7. Crossmember, Rear Floor Pan Rear exc.		3445022	#2.0	10.38
Station Wagon		3440842	#2.0	10.86
(#w/Necessary Bolted Parts Removed)				
8. Rail, Rear Floor Pan Side 2 Drs.		3611560-1	#7.5	65.04
4 Dr.		3611574-5	#7.5	65.04
Station Wagon		3611572-3	#7.5	65.04
(#w/Necessary Bolted Parts Removed)				

EXHAUST, Cont'd.

SINGLE EXHAUST SYSTEM, Cont'd.

6 CYL.

6. Pipe, Tail exc.	71	3404913	.6	8.13
	72	3404920	.6	7.60
Station Wagon	71	3583404	.6	10.29
	72	3583406	.6	10.29
Support w/Insulator, Tail Pipe				
7. Front		3466984		2.85
8. Rear exc.		3404943		1.46
Station Wagon		3583442		3.33
Clamp Pkg., Tail Pipe Support				
9. Front		1843010		.58
10. Rear	71	2240311		.64
	72	2279897		.64

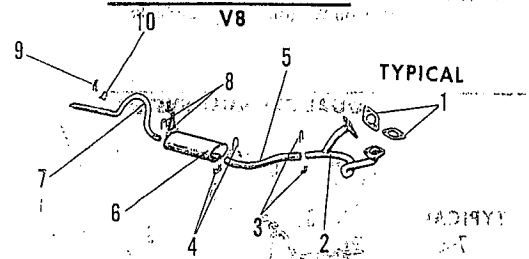

Manifold, Exhaust w/318	Rt.	2843966	.90	31.40
	Lt.	3512076	.8	30.75
w/383, 400 exc.	Rt.	3751072	1.0	33.65
	71 - Lt.	3751067	.9	45.85
	72 - Lt.	3751067	.9	45.85
w/400 w/E. C. S.*	Rt.	3614340		45.85
	Lt.	3614801		43.65

(*E. C. S. Indicates Emission Control System)

EXHAUST

Replace Exhaust System *
6 Cyl. 1.5
V8 Single 1.6, Dual 3.1
(*Includes R&R Clamps or
Supports as Necessary)
If Necessary to Cut Any Pipe
Add .3

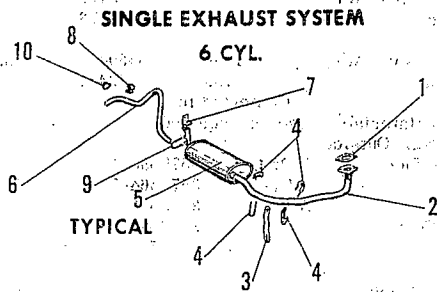

Manifold, Exhaust	2951841	2.7	34.35
Gasket Set, Manifold	3683826		1.57
1. Gasket, Exhaust Pipe Flange	3462399		.43
2. Pipe, Exhaust 2 Drs.	3466071	.9	14.65
4 Drs.	3404911	.9	14.00
3. Brace, Exhaust Pipe	3404598		1.50
4. Clamp Pkg., Exhaust Pipe (2)	1843010		.58
5. Muffler Zinc Coated	71 2781264	.8	19.70
	72 3583746	.8	19.70
Aluminized	71 2781263	.8	23.70
	72 3583745	.8	23.70

1. Gasket, Exhaust Pipe Flange w/383, 400	Rt.	2465391		.43
	Lt.	2856029		.43
2. Pipe, Exhaust w/318 All	71	3404914	1.0	19.95
exc.	72	3583902	1.0	30.00
Station Wagon	72	3583906	1.0	30.00
w/383	71	3466084	1.0	26.50
w/400 exc.	72	3583932	1.0	31.70
Station Wagon	72	3583934	1.0	31.70
Clamp Pkg., Pipe				
3. Exh. Pipe to Extension w/318	71	2883916		.69
w/383	71	2883919		.98
4. Exhaust Pipe to Muffler w/318	72	1843008		.69
w/400	72	1603364		.92
4. Extension to Muffler w/318	71	1843008		.69
w/383	71	1603364		.92
5. Extension, Exhaust Pipe (71 Only) w/318 2 Drs.		3466082		8.49
4 Drs.		3404919	.8	8.49
w/383 2 Drs.		3466091	.8	8.18
4 Drs.		3466089	.8	8.85
6. Muffler w/318 Zinc Coated		2781266	.8	19.70
Aluminized	71	2781265	.8	27.90
	72	3583904	.8 (D)	23.65
w/383, 400 Zinc Coated		2883912	.8	19.70
w/383 Aluminized	71	2925771	.8	27.10
w/400 Aluminized	72	3583836	.8	27.10

Cont'd.

Cont'd.

EXHAUST, Cont'd.

EXHAUST, Cont'd.

SINGLE EXHAUST SYSTEM, Cont'd.

DUAL EXHAUST SYSTEM, Cont'd.

V8

V8

7. Pipe, Tail				
w/318 exc.	3404920	.6	7.60	
Man. Trans. After *	3583798	.6	10.19	
Station Wagon	3583406	.6	10.29	
w/383, 400 exc.	3466092	.6	11.71	
Station Wagon	3583412	.6	12.61	
	(*Nov. 1, 1971)			
Support w/Insulator, Tail Pipe				
8. Front	3466984		2.85	
9. Rear exc.	3404943		1.46	
Station Wagon	3583442		3.33	
10. Clamp Pkg., Tail Pipe Rear Support				
w/318	2279897		.64	
w/383, 400 exc.	2240312		.64	
Station Wagon	2585698		.58	

5. Pipe, Tail				
w/o Decor. Extensions				
exc.	3466092-3	.6	11.71	
w/440 w/3-2 Bbl.	71 3466102-3	.6	9.25	
w/440	72 3466978-9	.6	10.10	
S/W w/383, 400	Rt. 3583414	.6	18.49	
	Lt. 3583405	.6	18.49	
w/Decor. Extensions	3466102-3	.6	9.25	
Support w/Insulator, Tail Pipe				
6. Front				
Rt.	3466984		2.85	
Lt.	3466191		(D) 1.80	
7. Rear w/o Decor. Ext.				
exc.	Rt. 3404943		1.46	
	Lt. 3466060		1.46	
Station Wagon	3583442-3		3.33	
Bracket, Tail Pipe Front Supt. Lt.	3466061		1.70	
Clamp Pkg., Tail Pipe				
8. Front Support	Rt. 3466987		.45	
9. Rear Support				
exc.	2240312		.64	
w/426, 440 w/3-2 Bbl.	2883919		.98	
Extension, Tail Pipe Decor.				
exc.	3466123	.4	26.34	
w/426, 440 w/3-2 Bbl.	3466113	.4	19.15	
Support, Tail Pipe Extension	3466199		2.06	
Clamp Pkg., T/Pipe Extension	3466613		1.10	

DUAL EXHAUST SYSTEM

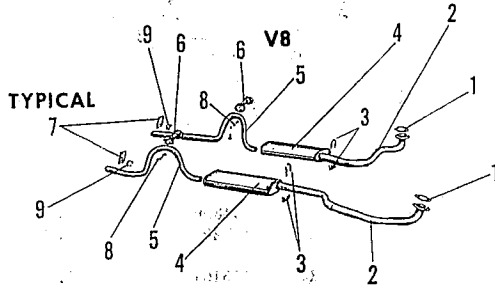

Manifold, Exhaust				
w/340	Rt. 3418624	1.3	45.85	
	Lt. 3418620	1.8 (D)	33.74	
w/383, 400, 440 exc.	Rt. 3751069	1.0	33.65	
	71 Lt. 3751067	.9	45.85	
	72 Lt. 3751067	.9	45.85	
w/400, 440 w/E. C. S. *	Rt. 3614340		45.85	
	Lt. 3614801		43.65	
w/426	(71) Rt. 3577282	2.3	121.09	
	Lt. 3418452	2.0	101.78	
	(*E. C. S. Indicates Emission Control System)			
1. Gasket, Exhaust Pipe Flange				
w/383, 400, 440	(2) 2856029		.43	
2. Pipe, Exhaust				
w/340	Rt. 3583654	.7	23.00	
	Lt. 3583725	.7	23.00	
w/383, 400 2 Drs.	3466095-8	.7	15.00	
4 Drs.	3404923-4	.7	15.00	
w/426 ("H" Shaped)	3466116	.7	54.58	
(to Intake Manifold)	2781278	.7	8.82	
w/440 2 Drs.	3466994-5	.7	20.80	
3. Clamp Pkg., Exhaust Pipe to Muffler				
w/383, 400	1603364		.92	
w/426, 440	2883919		.98	
Clamp Pkg., Int. Manif. Exh. Pipe	2781273		.98	
4. Muffler, Front				
exc.	Zinc Coated (2) 2883912	.9	19.70	
	Aluminized Rt. 2883910	.9	29.80	
	Lt. 2883911	.9	27.10	
w/Noise Reduction Pkg.				
w/383	Zinc Coated (2) 3583829	.9	19.70	
	Aluminized Rt. 3466298	.9	30.65	
	Lt. 3583827	.9	27.10	
w/400	Zinc Coated (2) 3583829	.9	19.70	
	Aluminized Rt. 3583826	.9	30.65	
	Lt. 3583827	.9	27.10	
w/426	3404839	.9	33.98	
Muffler, Rear (*Resonator) (71 Only)				
w/426, 440 **	3466120-1	.8	34.65	

WINDSHIELD

Add to Glass R&R to Check Opening Order Installation Materials as Required

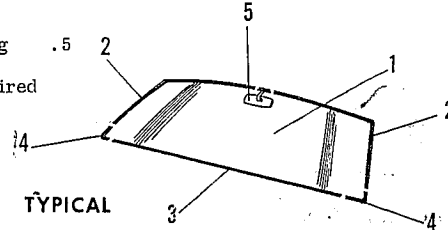

1. Glass, Windshield	(Glass Co.)		(Car Mfr.)
2 Drs.			
Clear NAGS W776	Use 3439472*	2.5	Use Glass
Tinted	Glass 3439473*		
4 Drs.			
Clear NAGS W777	Price 3439480*	2.5	Price List
Tinted	List 3439481*		
	(*Cemented in Type)		
Installation Materials - Use as Required			
Moulding Pkg., Outside			
2. Upper & Side	2 Drs. 3579580-1	#	6.73
	4 Drs. 3579564-5	#	5.75
3. Lower	All 3579553	#	11.82
4. Lower Corner	2 Drs. 3579578-9	#	2.37
	4 Drs. 3579566-7	#	2.37
	(# One .5, All .8)		
Moulding, Garnish			
Upper (Prime)	2 Drs. 3439488		5.17
	4 Drs. 3439489		5.17
Side (Black)*	2 Drs. 3760-1GX9		5.50
	4 Dr. 3794-5GX9		4.19
	S/W 3792-3GX9		4.19
5. Mirror, Inside Rear View			
Plain	3695132	.2	4.17
Prismatic	71 3695130	.2	7.52
	72 3695130	.2	7.52
Bracket w/Shaft, Inside Mirror	3508523		4.64
Panel, Sun Visor (Green)*	71 1123GF7	.2	11.38
	72 1141HF6	.2	11.38
	(*For Colors Not Listed, Call Local Dealer)		
Arm & Bracket, Visor To 9-70	71 2878882		3.59
After 9-70	71-72 3586983		3.59

Cont'd.

Cont'd.

OCTOBER 1, 1974

DODGE

CORONET & CHARGER 1971-72

WINDSHIELD, Cont'd.

WIPER & WASHER PARTS

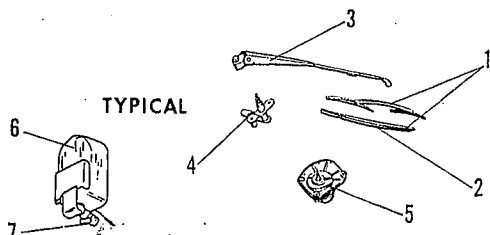

1. Blade w/Refill, Wiper					
To 9-30-70	3431251		3.50		
From 9-30-70	3431465		3.50		
2. Refill, Blade					
To 9-30-70	3431255	.2	2.30		
From 9-30-70	3431466	.2	2.30		
3. Arm w/o Blade, Wiper					
Trico or Anco	Rt. 3431098	.2	6.00		
	Lt. 3431097	.2	8.45		
4. Pivot, Wiper (thru Cowl)					
To 6-72	3514444-5	1.1	5.29		
From 6-72	3621898-9	1.1	5.29		
5. Motor, Wiper					
2 Speed	71 3744854	.8	48.82		
To 6-72	72 3431606	.8	51.84		
From 6-72	72 3431606	.8	51.84		
Variable (3 Speed)	71 3431077	.8	47.39		
	72 3431624	.8	52.00		
6. Reservoir, Washer					
w/Variable (3 Speed)	71 3431074	.3	3.73		
	72 3431590	.3	3.73		
7. Pump, Washer					
	71 2809013	.3	10.65		
	72 3431599	.3	11.19		
Nozzle, Washer	(2) 3431160	.2	1.18		

COWL and DASH, Cont'd.

5. Extension, Frame Upper Corner					
2 Drs.	3439414-5		4.13		
4 Drs.	3439416-7		3.47		
6. Panel, Cowl Top & Dash					
w/o A. C.	3482086	#8.0	123.42		
w/A. C.	3611349	#8.0	123.42		
(#w/Doors, Fenders, W/Shield Glass & Instr. Panel Cover Rem.)					
Screen, Cowl Top	3500758-9		.99		
7. Panel, Instrument					
w/o A. C.	3590284		88.19		
w/A. C.	3590286		88.19		
8. Door, Glove Box (Prime)	3590280	.3	4.58		
9. Pad, Inst. Panel Trim (Black) *	4203GX9	3.2	57.27		
(*For Colors Not Listed, Call Local Dealer)					
Tape Pkg., Cowl Top Stripe*					
71 Charger SE					
Up to 12-1-70	Blue 3612953		6.08		
	Green 3612954		6.08		
After 12-1-70	Green 3613525	(D)	4.96		
	Blue 3613526	(D)	4.96		
	Gold 3612955				
	Black 956				
	White 957				
(*Pkg. Incl. Quarter & Roof Transverse for One Side)					
(NOTE: Check Local Dealer for Availability of Separate (Cowl Only) Tapes.					

COWL and DASH

Refinish Upper Panel	1.0		
exc.	1.0		
w/2 Tone Paint	1.5		
Pillar	1.0		
R&R Pillar w/Roof Rem.	6.0		

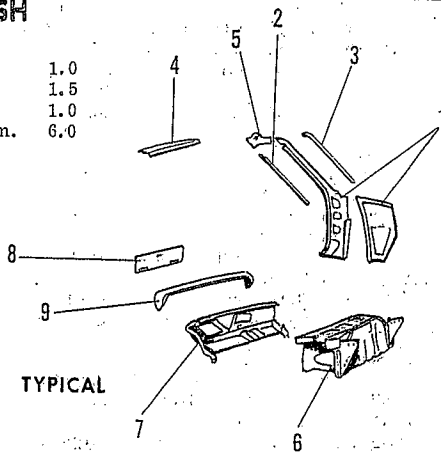

1. Panel, Cowl Side (Includes Pillar)					
2 Drs.	3482102-3	#	77.27		
4 Drs.	3482100-1	#	77.27		
(#R&R Complete w/Fender, Doors & W/Shield Removed 8.0, Cut Below Belt w/Fender & Door Removed 5.6)					
2. Trough, Front Pillar Drain					
2 Drs.	3720548-9		4.19		
4 Drs.	3720500-1		4.19		
3. Moulding, Front Pillar Drain Trough					
2 Drs. - See Roof-Side Drain Trough Midg.					
4 Drs. w/o Vinyl Roof	3749054-5	.2	1.76		
w/Vinyl Roof	3749056-7	.2	1.76		
4. Frame, Windshield Opening Upper					
2 Drs.	3482145	#1.5	18.89		
4 Drs.	3482144	#1.5	18.89		
(# w/Roof Removed)					

ROCKER PANEL & CENTER PILLAR

Refinish Rocker Panel	1.0		
Cut & splice under door(s) between pillars and within the flat section of door sill.			
One Door	2.5		
Both Doors & Center Pillar	4.5		
R&R Rocker Panel			
a. w/Hinge Pillar Removed			
2 Dr. 3.0	4 Dr. 4.0		
b. w/Lock Pillar Removed			
2 Dr. 3.0	4 Dr. 4.0		
c. w/Both Pillars Removed			
2 Dr. 2.0	4 Dr. 3.0		
Time Does Not Include Remove Front Fender.			

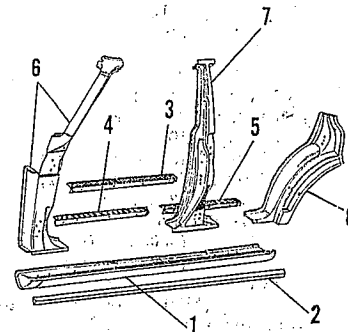

ROCKER PANEL

1. Panel, Rocker (Sill) Outer					
2 Drs.	3445402-3		4.5	23.58	
4 Dr. Sed.	3616504-5		5.0	23.58	
S/W	3720456-7		5.0	23.58	
2. Moulding Pkg., Rocker or Sill*					
2 Drs. exc.	(2) 3504725	.5	5.78		
Charger 500	71 3620058-9	.5	7.03		
4 Drs.	(2) 3504724	.5	5.71		
(*Pkgs. Include Attaching Parts)					
Panel, Rocker or Sill Inner					
Front	71 3570394-5		10.27		
	72 3615716-7		10.27		
Rear 2 Drs.	71 3615712-3		4.85		
	72 3615712-3		4.85		
4 Drs.	71 3445004-5		4.85		
	72 3756150-1		4.85		
Plate, Door Sill Scuff					
3. 2 Drs.	(2) 3416002	.2	6.08		
4. 4 Drs. Front	3416004-5	.2	4.70		
5. Rear	3416006-7	.2	4.31		

PILLARS

Refinish Center Pillar Complete	1.0		
R&R Center Pillar			
w/Roof or Rocker Rem.	3.5		
w/Roof & Rocker Rem.	2.0		
6. Pillar, Front Hinge - See Item 1 in Cowl & Dash Section			
7. Pillar, Center	71 3482138-9	4.0	54.44
	72 3611236-7	4.0	54.44
8. Pillar, Rear Body Lock - See Quarter Panel Section.			

Cont'd.

SEAT

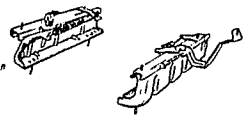

Adjuster, Seat (Manual) w/Bench Seat	71	3670242-3	#.6	11.18
	72	3670242-3	#.6	11.18
w/Bucket or Split Seat Drivers Side				
Outer	71	3586137	#.6	12.57
	72	3670241	#.6	12.57
Inner	71	3586145	#.6	12.57
	72	3670239	#.6	11.18
Passenger Side				
Outer	71	3586136	#.6	12.57
	72	3670240	#.6	12.57
Inner	71	3586144	#.6	12.57
	72	3670238	#.6	11.18
6 Way (Left)	71	3508217		66.87
	72	N.A.		N.A.

(#R&R Both On One Side .9)

Seat Belt, Front (Black)* Lap - Tip Half				
71	N.A.	N.A.		N.A.
72	(3670910-1)	9994-5HX9		15.44
	(3670154-5)	9994-5HX9		15.44
Lap - Buckle Half				
71	N.A.	N.A.		N.A.
72 2 Drs. (3670524)		9941HX9		9.39
All (3670794)		9924HX9		9.39
Lap - Center Belt				
71 (Pkg.) (2999601)		4724FX9		14.70
		9015GX9		15.44
72 (Tip-Half)		9917HX9		8.43
72 (Buckle-Half)		9918HX9		9.86
Shoulder, Belt Harness				
71 (Tip Half)				
2 Drs. (3508289)	(2)	9027GX9		9.54
4 Drs. (3508290)	(2)	9030GX9	(D)7.10	17.10
S/W (3508296)	(2)	9044GX9	(D)7.10	17.10
71 (Buckle Half)				
All (3508286-7)		9036-7GX9		18.55
		9028-9GX9	(D)17.35	17.35
72 (Pkg.)		9900HX9		9.54

(*For Colors Not Listed, Call Local Dealer)
NOTE: Number in Parenthesis is Label I. D. Number.

FRONT DOOR, Cont'd.

MOULDINGS & TRIM
(Pkgs. Include Attaching Parts)

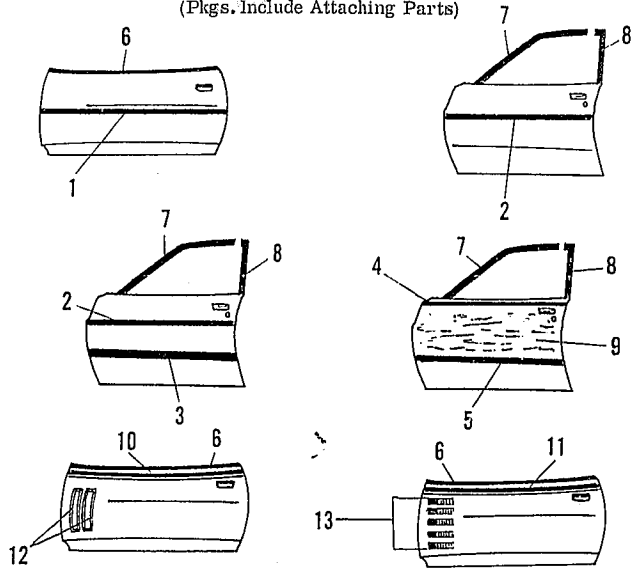

Moulding Pkg., Side				
1. All 2 Drs. To 8-1-71 71-72		3613467	.3	6.04
After 8-1-71 72		3680669	.3	6.04
4 Drs. exc. Crestwood S/W				
2. Upper				
Plain	71	3620504-5	.3	3.93
	72	3685002-3	.3	5.98
Painted	71	3579404-5	.3	4.48
w/Black Insert exc.		3579402-3	.3	6.92
Custom	72	3685004-5	.3	7.22
w/Insert	71			
Gold		Green	Blue	
3579986-7		988-9	990-1	.3
8.40				
3. Lower (Brougham Only)	71	3579414-5	.3	5.04
4 Dr. Crestwood S/Wagon				
4. Upper (Right)	71	3579452	.3	4.36
Front (Left)	71	3620056	.3	2.37
Rear (Left)	71	3620057	.3	4.24
4. Upper	72	3685004-5	.3	7.22
5. Lower		3579414-5	.3	5.04
6. Mldg. Pkg., Belt 2 Drs.		3620516-7	.3	10.46
Mldg., Window Frame Opening				
7. 4 Drs. Upper & Front		3439712-3	#	2.42
8. Rear		3439716-7	#	1.88
				(#R&R One or Both .3)
9. Overlay, Wood Grain				
Crestwood Station Wagon		3680107	#	23.33
(#1.5 w/Mldgs. Removed & After Painting)				
10. Tape, Side Stripe				
71 Super Bee, R/T*				
w/o Mirror	Black	3685200-1	#.6	22.55
w/Mirror	Black	3685202-3	#.6	22.37
71 Charger SE				
Right	White	3612760	.6	6.08
Black	Gold	Green	Blue	
3612761	762 (D)	763 (D)	764 (D)	.6
6.08				
Left Front	White	3612765 (D)	.6	1.02
Black	Gold	Green	Blue	
3612766	767 (D)	768 (D)	769 (D)	.6
1.25				
Left Rear	White	3612780 (D)	.6	2.88
Black	Gold	Green	Blue	
3612781	782	783	784	.6 (D)
2.88				
11. 72 Charger (Pkg.)*	Blue	3685304-5	#.6	18.04
Green	White	Black	Gold	
3685306-7	308-9	310-1	312-3	#.6
18.04				
(*Pkg. Incl. Fender & Quarter for One Side)				
(#Time is for Door Only)				
(NOTE) Check Local Dealer for Availability of Separate (Door Only) Tapes.				
12. Tape, Side Depression				
71 R/T Front		3612628-9	.3	.79
Rear		3612630-1	.3	.79
Pkg. (Frt. & Rr.)		3685232-3		1.58
13. 72 Rallye	(10)	3613437	.3	1.25

Cont'd.

FRONT DOOR

Refinish O. S.	2 Dr.	2.5
	4 Dr.	2.0
Jams, Add		.5
Charger, Add		.5
Add to Door or Outer Panel R&R		
w/Mirror Standard		.4
Remote Control		.7
w/Electric Lifts		.6
to Drill for & Install		
one Mldg.		.3
Ba. add'l. Mldg.		.2
for Stripe Tape		.6
R&I Door Assy.		
exc.		1.0
w/Electric Lifts		1.3
R&I Trim Panel		.4
Overlay & stripe tape time		
does not include removal of		
old overlay or tape.		

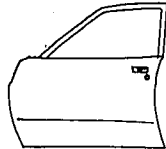

SHEET METAL

Shell, Door				
2 Drs. exc.		3482050-1	#3.5	148.51
R/T	71	3482048-9	#3.5	148.51
Rallye	72	3611456-7	#3.5	148.51
4 Drs.		3684122-3	#3.5	161.83
Panel, Outer Repair				
2 Drs. exc.		3482052-3	#4.5	50.80
R/T	71	3482074-5	#4.5	50.80
Rallye	72	3611458-9	#4.5	50.80
4 Drs.		3482058-9	#4.5	48.81

(#See Note Above for Additional Time) Cont'd.

OCTOBER 1, 1974

DODGE

CORONET & CHARGER 1971-72

FRONT DOOR, Cont'd.
MOULDINGS & TRIM, Cont'd.



14. Mirror, Outside Rear View					
Manual					
Round (Chrome)					
2 Drs.	Lt.	3586645	1#	8.03	
4 Drs.	Rt.	3586738	1#	8.03	
	Lt.	3586739	1#	8.03	
Racing					
2 Drs.	Chrome Rt.	3586644	1#	13.41	
	Prime Rt.	3586650	1#	11.70	
Remote Control					
Round (Chrome)					
4 Drs.	Lt.	3586643	2#	19.41	
Racing					
2 Drs.	Chrome Lt.	3586977	2#	24.51	
	Prime Lt.	3586976	2#	23.12	
(1# R&R .2, Install .4) (2# R&R .4, Install .7)					

HARDWARE

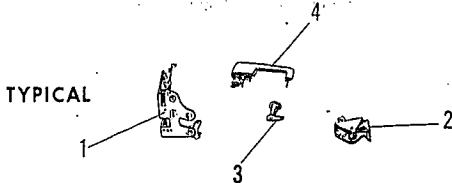

1. Lock or Latch					
	Rt.	3695440	.6	13.29	
	Lt.	3548565	.6	13.92	
Striker, Lock					
2 Drs.		3454485	.2	2.04	
4 Drs.		3454484	.2	2.04	
2. Remote Control, Lock					
3. Cyl. & Key Pkg., Door & Ignition					
exc. Station Wagon					
w/o Tilt Wheel					
	71	2999444	#	8.83	
	72	3670672	#	10.59	
w/Tilt Wheel					
		3548955	#	6.64	
Station Wagon (Includes Tailgate)					
Manual Gate					
	71	3508876	#	12.36	
	72	3670674	#	12.62	
w/Tilt Wheel					
Electric Gate					
	71	N.A.	#	N.A.	
	72	3695162	#	13.35	
		3548958	#	10.27	
(R&R Each Door .5, Drs. & Ign. 1.2, Drs., Ign. & T/Gate 1.9)					
4. Handle, Outside					
2 Drs.	71	3621757	.5	7.47	
4 Drs.	71	3621755	.5	7.47	
To 6-72	All	72	3586024	.5 (D)	5.87
From 6-72	2 Drs.	72	3621757	.5	7.47
	4 Drs.	72	3621755	.5	7.47
Inside					
2 Drs.		3508916	.2	2.28	
4 Drs.		2935214-5	.2	2.28	
Hinge, Door					
Upper	(2)	3454510	.8	7.65	
Lower		3454512-3	.6	12.09	
Weatherstrip, Door (On Door)					
2 Drs.		3439734-5	.6	10.86	
4 Drs.		3439736-7	.6	12.68	

DOOR GLASS & PARTS

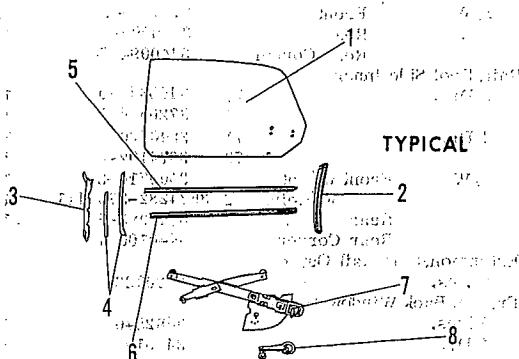

Cont'd.

FRONT DOOR, Cont'd.

DOOR GLASS & PARTS, Cont'd.

1. Glass, Door		(Glass Co.)		(Car Mfr.)	
2 Drs.					
	Clear	NAGS D4582-3	Use	3439900-1	1.1 Use
	Tinted		Glass	3439902-3	Glass
4 Drs.					
	Clear	NAGS D4589-90	Price	3581768-9	1.1 Price
	Tinted		List	3581770-1	List
2. Channel w/Stabilizer, Glass Lift					
2 Drs.	To 11-1-70			3499248-9	5.82
	From 11-1-70			3582038-9	5.82
4 Drs.				3582034-5	3.85
3. Track, Glass					
2 Drs.	Front	71		3499274-5	3.59
		72		3499274-5	3.59
	Rear To 12-70	71		3581112-3	3.59
	After 12-70	71		3581912-3	3.59
		72		3581914-5	3.59
4 Drs.				3499272-3	3.59
Channel & Run, Door Frame					
Upper Extension 4 Drs.					
				3581680-1	5.50
Run (Only), Door Frame					
Upper Extension (2) 4 Drs.					
				3581478	2.16
Run, Glass To 11-71					
				3582316-7	4.16
	After 11-71			3696440-1	4.37
4. Run, Glass Track Stab. Guide					
Weatherstrip, Glass Belt					
5. Outer					
2 Drs.	To 1-72	71-72		3581154-5	#.3 3.47
	After 1-72	72		3696360-1	#.3 3.47
4 Drs.				3582318-9	#.3 3.47
Inner	2 Drs.			3416196-7	#.3 5.43
	4 Drs.	(2)		3416360	#.3 2.49
#.2 w/Glass Removed					
7. Regulator, Glass					
Manual 2 Drs.					
				3695672-3	.9 16.93
	4 Drs.			3695674-5	.7 16.93
Electric 2 Drs.					
				3548750-1	1.0 17.78
	4 Drs.			3548748-9	1.0 17.78
8. Handle, Regulator					
Motor w/Mechanism, Regulator					
2 Drs.				3548746-7	1.1 46.92
4 Drs.				3508206-7	1.1 46.92

REAR DOOR

Refinish O.S.	2.0
Jams, Add	.5
Add to Door or Outer Panel R&R	
to Drill for & Install	
one Mldg.	.3
Ea. add'l. Mldg.	.2
R&I Door Assy.	.8
R&I Trim Panel	.4
Overlay time does not include	
removal of old overlay.	

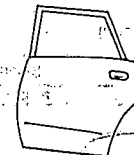

SHEET METAL

Shell, Door			
4 Dr.	3684344-5	#3.2	161.83
Station Wagon	3684348-9	#3.2	161.83
Panel, Outer Repair	3440004-5	#4.5	48.81

(#See Note Above for Additional Time)

Cont'd.

REAR DOOR, Cont'd.

MOULDINGS & TRIM

(Pkgs. Include Attaching Parts)

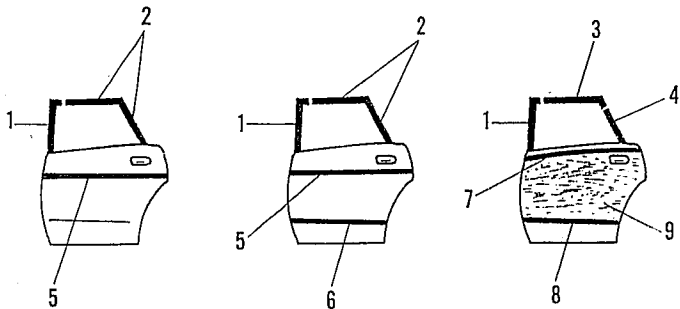

Mldg.	Window Frame Opening			#	
1.	Front	All	3440030-1	#	1.88
2.	Upper & Rear	4 Dr.	3440032-3	#	2.11
3.	Upper	S/W	3440034-5	#	1.88
4.	Rear	S/W	3440036-7	#	1.62

(#One or All .3)

Moulding Pkg., Side

exc. Crestwood Station Wagon

5.	Upper				
	Plain	71	3579462-3	.3	3.93
		72	3685006-7	.3	5.72
	Painted	71	3579408-9	.3	4.10
	w/Black Insert exc.		3579406-7	.3	6.41
	Custom	72	3685008-9	.3	6.97
	w/Insert	71			
	Gold	Green	Blue		
	3579992-3	994-5	996-7	.3	7.91
6.	Lower (Brougham Only)		3579416-7	.3	4.48
7.	Crestwood S/W	Upper	3579454-5	.3	3.25
8.		Lower	3579416-7	.3	4.48
9.	Overlay, Wood Grain			#	
	Crestwood Station Wagon		3680107	#	23.33

(#1.5 w/Mldgs. Removed & After Painting)

HARDWARE

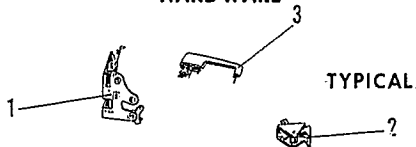

1.	Lock or Latch		3695460-1	.6	13.92
	Striker, Lock		3454485	.2	2.04
2.	Remote Control, Lock		3454940-1		3.85
3.	Handle, Outside	71	3621756	.5	7.47
	To 6-72	72	3586024	.5 (D)	5.87
	From 6-72	72	3621756	.5	7.47
	Inside		2935214-5	.2	2.28
	Hinge, Door Upper		3454504-5	.4	7.47
	Lower		3454506-7	.8	11.87
	Weatherstrip, Door (On Door)				
	4 Dr.		3440042-3	.6	13.07
	Station Wagon		3440044-5	.6	13.07

DOOR GLASS & PARTS

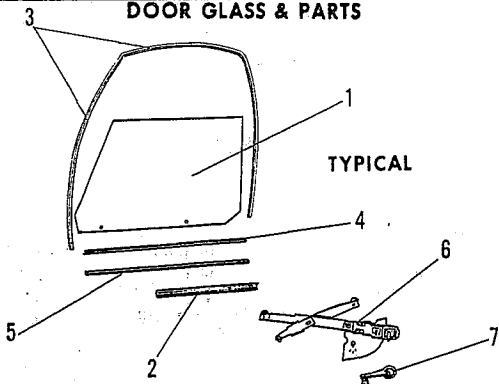

Cont'd.

REAR DOOR, Cont'd.

DOOR GLASS & PARTS, Cont'd.

	(Glass Co.)		(Car Mfr.)	
1.	Glass, Door			
	4 Dr.			
	Clear NAGS D4591-2	Use	3440070-1	1.0
	Tinted	Glass	3440072-3	
	Station Wagon			
	Clear NAGS D4594-5	Price	3440074-5	1.0
	Tinted	List	3440076-7	
2.	Channel, Glass Lift		3440540	2.54
3.	Run, Glass	4 Dr.	3440038	.8
	S/W		3581877	.8
	Weatherstrip, Glass Belt			
4.	Outer		3440062-3	#.3
5.	Inner		3416362	#.3
				2.49
				2.37
				(# .2 w/Glass Removed)
6.	Regulator, Window			
	Manuel		3695002-3	.9
	Electric		3548802-3	1.0
7.	Handle, Regulator		2862167	.2
	Motor w/Mechanism, Regulator		2999338-9	
				46.92

ROOF

Refinish Roof				
exc.		4.2		
Station Wagon		4.8		
R&R Headliner				
One Piece Type		4.6		
Sectional Type (S/W)				
1st or 7th		.7		
2nd thru 6th (Each)		.4		
Complete		2.1		
Rail Time is w/Roof Rem.				
Add to Roof R&R				
w/Vinyl Cover				
exc.		6.0		
Partial Cover		4.0		
w/Luggage Rack		2.0		

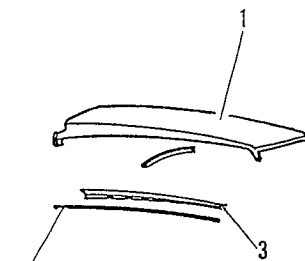

TYPICAL

1.	Panel, Roof				
	2 Drs. w/o Sun Roof		3445833	19.0	75.08
	w/Sun Roof		N. A.		N. A.
	4 Dr.		3445101	19.0	75.08
	Station Wagon		3440088	20.0	142.43
2.	Trough, Roof Side Drain				
	2 Drs.		3505256-7	#1.5	7.52
	4 Dr.	Front	3445110-1	#1.5	7.77
		Rear	3445112-3	#1.5	3.85
	S/W	Front	3440110-1	#1.5	7.52
		Inter.	3440112-3	#1.5	8.17
		Rear	3440114-5	#1.5	3.59
					(# w/Roof Removed)
	Cover, Drain Trough Joint		2571768		.13
3.	Rail, Roof Side Outer				
	2 Drs.	71	3445842-3	2.0	5.75
		72	3445842-3	2.0	5.75
	4 Dr.		3445104-5	2.0	4.97
	S/W	Front	3767118-9	1.5	4.97
		Rear	3440092-3	1.5	8.38
		Rear Corner	3440094-5	1.5	5.50
	Rail, Roof Side Inner				
	2 Drs.	71	3445848-9	1.0	6.54
		72	3720654-5	1.0	6.54
	4 Dr.	71	3500720-1	1.0	5.82
		72	3674192-3	1.0	5.82
	S/W	Front w/Nut	3500714-5	1.0	6.86
		w/Reinf.	72 3674282-3767111	1.0	6.86
		Rear	3440098-9	1.5	5.50
		Rear Corner	3440100-1	1.0	5.82
	Extension, Side Rail Outer				
	2 Drs.		3720026-7		10.78
	Frame, Back Window Upper				
	2 Drs.		3482546	1.5	10.26
	4 Dr.		3445107	1.5	4.37

Cont'd.

OCTOBER 1, 1974

DODGE

CORONET & CHARGER 1971-72

ROOF, Cont'd.

Header, Roof Rear (S/W)	3482547	#	22.62
(#2: 5 w/ Roof Panel Removed)			
Deflector, Roof Rear Air (S/W)	3579672		22.75
Weatherstrip, Side Rail* (2 Drs.)	3581958-9	.3	15.89
Retainer, Side W/Strip* (2 Dr.)	3439452-3	.5	6.13
(*Includes Front Pillar)			

MOULDINGS & TRIM

(Pkgs. Include Attaching Parts)			
Moulding, Side Drain Trough w/o Vinyl Roof			
2 Drs.	3612914-3749063	.3	4.05
4 Dr.	3445118-9	.3	3.01
Station Wagon w/Vinyl Roof	3504848-9	.3	6.22
2 Drs.* exc.	3612912-3	.3	4.05
Charger "SE" 72	3613262-3	.3	4.37
4 Dr.	3504844-5	.3	3.01
(*Includes Front Pillar)			
Moulding Pkg., Roof Transverse Charger	3621583		8.38
Cover, Vinyl Roof (Black)*			
2 Drs. exc. (Full)	6109GX9	#7.5	103.17
"SE"	6108GX9	#5.5	103.17
	6107HX9	#5.5	103.17
(Canopy) 72	6108GX9		103.17
4 Dr.	6111GX9	#7.3	103.17
(#R&R w/o Removal of W/Shield or Back Glass, Includes R&R Mldgs. of Windshield & Back Glass)			
Tape Pkg., Roof Transverse Stripe*			
71 Charger SE			
Up to 12-1-70	Blue 3612953		6.08
	Green 3612954		6.08
After 12-1-70	Green 3613525	(D)	4.96
	Blue 3613526	(D)	4.96
Gold Black White	956 957		6.08
(*Pkg. Incl. Cowl & Quarter for One Side)			
(NOTE: Check Local Dealer for Availability of Separate (Roof Only) Tapes.			
Nameplate, Side (Brougham)	71 3504323	#	3.13
(#1.0 exc. w/Headliner-Loose .2)			

LUGGAGE RACK PARTS (S.W.)

Factory Installed Type

R&R	1.0
Install Including Drilling	2.0

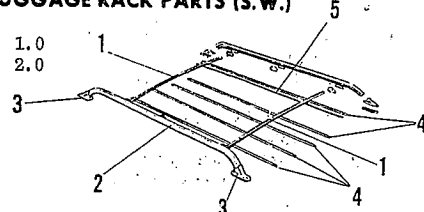

Luggage Rack Pkg.*	3720726		58.10
(*Complete Pkg. for Field Installation)			
1. Rail, Front or Rear	3499331	*	6.86
	3720133	**	6.99
2. Side	3499798	*	16.09
	3720125	**	16.09
3. Stanchion, Side Rail	3499828-9	*	9.02
	3720126-7	**	9.02
4. Strip, Skid (5)	3439314	*	7.32
	3720139	**	7.32
5. Pad, Skid Strip (5)	3439315	*	1.97
	3720137	**	1.97
(*To Jan 1972) (**From Jan. 1972)			

BACK WINDOW

Order Installation Materials as Required

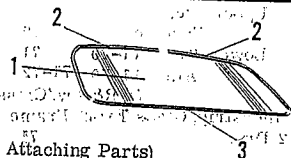

(Pkgs. Include Attaching Parts)

1. Glass, Back Window *	(Glass Co.)	(Car Mfr.)	
2 Drs.			
Clear NAGS B4586	Use Glass 3445827	Use Glass 3445828	2.0
Tinted			
4 Drs.			
Clear NAGS B4593	Price List 3445126	Price List 3445127	2.0
Tinted			
(*Cemented in Type)			

BACK WINDOW, Cont'd.

Installation Materials - Use as Required			
Louvre Pkg., Window Outside			
2 Drs.	71 3570576		128.76
Hinge, Louvre			
2 Drs.	71 N.A.		N.A.
Moulding Pkg., Outside			
2. Upper & Side			
2 Drs.	Bright 3579576-7	#	5.55
	Black * 3579620-1	#	8.17
	3579562-3	#	5.17
3. Lower 2 Drs.	Bright 3579588-9	#	3.99
	Black * 3579618-9	#	6.13
4 Dr.	3579560-1	#	4.05
(*For Colors Not Listed, Call Local Dealer) (# One .5, All .8)			
Moulding, Garnish (Prime)			
2 Drs.	Side & Upper 3446588-9		3.27
	Lower 3499866-7		3.27
4 Drs.	Side & Upper 3446594-5		3.27
	Lower 3499868-9		3.27

QUARTER PANEL

EXC. STATION WAGON

Refinish O.S.	2 Drs.	3.0
	4 Drs.	2.4
Pillar Add		.3
Inner Panel Time is w/Outer Rem.		
R&I Trim Panel		.5
R&R Quarter w/Roof Removed		
2 Drs.	12.5, 4 Drs: 10.0	
Cut at Belt Line & Around B/Wind.		
2 Drs.	#13.5, 4 Drs: 12.5	
(#Charger 2 Dr. H.T. - Cut Along Belt Line to Deck Opng. 14.0		
Add to Quarter R&R to Drill for & Install one Mldg.		.4
Ea. add'l. Mldg.		.2
Nameplate w/Electric Lifts		.3
w/Vinyl Roof Cover exc.		1.5
2 Dr. H.T. for Stripe Tape		2.0
Overlay or stripe tape time does not include removal of old overlay or tape.		.8

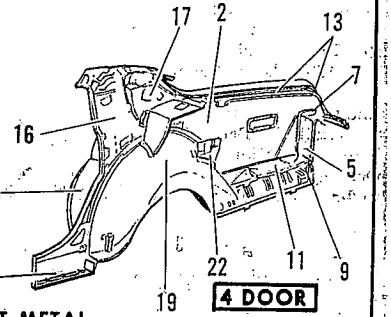
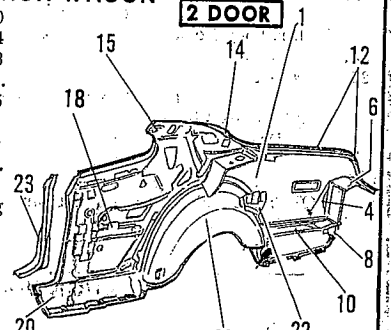

SHEET METAL

Panel, Outer Repair			
1. 2 Drs.	71 3445584-5	#16.0	132.48
	72 3615210-1	#16.0	132.48
2. 4 Dr.	71 3615260-1	#14.0	101.97
	72 3615212-3	#14.0	101.97
(#See Note Above for Additional Time)			
3. Extension, Outer Panel End			
2 Drs.	3445520-1	.3	5.75
4. Extension, Outside Panel Rear Flange			
2 Drs.	3570224-5	#1.0	12.02
5. 4 Drs.	3446038-9	#1.0	11.51
6. Extension, Deck Panel Reinf.			
2 Drs.	3504312-3	#.5	3.27
4 Drs.	3446524-5	#.5	2.62
7. Extension, Floor Pan Rear X-Mbr.			
2 Drs.	3504584-5	#.5	2.28
4 Drs.	3445024-5	#.5	2.28
8. Extension, Floor Pan Side			
2 Drs.	3445528-9	#1.5	16.28
4 Drs.	3445070-1	#1.5	16.28
(#w/Quarter Panel Removed)			
9. Trough, Deck Drain			
2 Drs.	3445684-5	#1.3	6.54
4 Drs.	3445082-3	#1.3	7.77
(# exc. w/Quarter Panel Removed .8)			

Cont'd.

Cont'd.

QUARTER PANEL, Cont'd.

EXC. STATION WAGON, Cont'd.

SHEET METAL

14.	Panel, Inner					
	Upper	2 Drs.	3500378-9	1.5	13.79	
15.	Upper Front	2 Drs.	3500668-9	1.5	7.07	
16.		4 Drs.	3445052-3	1.5	9.54	
17.	Upper Rear	4 Dr.	Rt. 71 3445054	1.5	9.54	
			Lt. 71 3500995	1.5	9.54	
			72 3500994-5	1.5	9.54	
18.	Lower	2 Drs.	3445586-7	1.5	13.79	
19.	Panel, Wheelhouse					
	Outer		71 3445604-5	2.5	20.20	
			72 3615312-3	2.5	20.20	
	Inner		3445058-9	2.5	20.20	
	Plate, Side Sill Tie					
20.	To Inner Panel	2 Drs.	3445504-5		3.27	
21.	To Wheelhouse	4 Dr.	3505494-5		3.59	
	Support, Deck Lid Hinge					
	Upper *	2 Drs.	3506278-9		3.92	
		4 Dr.	3506210-1		3.92	
22.	Lower	All	3445074-5		2.54	
			(*Not Illustrated)			
	Pillar, Body Lock					
23.	2 Drs.		3445616-7	#	15.35	
24.	4 Dr.		3445060-1	#	15.35	
			(# 5.0 exc. w/Quarter Removed 3.0)			
	Reinf., Lock Pillar					
	2 Drs.		Upper 3615044-5	1.43		
			Lower 3445624-5	2.81		
	4 Dr.		3440180	.53		

NOTE: For Side Rails - See Frame Section.

STATION WAGON

Refinish O.S. 2.7
 Pillar, Add .3
 Inner Panel Time is w/Outer Panel Removed
 R&I Trim Panel .5
 R&R Wheelhouse Cover Rt. .5, Lt. 1.0
 Add to Quarter R&R to Drill for Each Mldg. .2 for Gas Filler 1.0
 Overlay time does not include removal of old overlay.

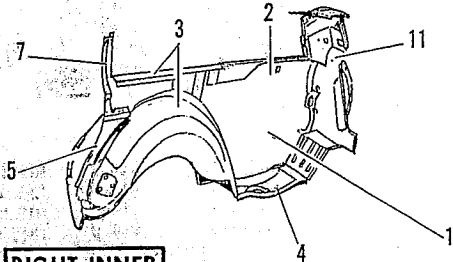
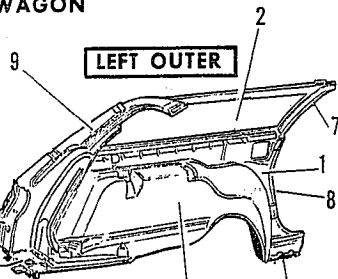

SHEET METAL

1.	Panel, Outside Repair		3720004-5	12.5	101.97
	Extension, Outside Panel End				
	End		3440158-9	#	6.01
	Rear Upper		3440514-5		8.17
	Rear Supt. to Front Supt.		3499410		12.47
			(# 1.0 Includes R&R Tail Lamp)		
2.	Panel, Inner				
	Front				
		Rt.	3611554	7.38	
		Lt.	3439527	4.58	
	Center				
		Rt. 71	3440864	6.54	
		72	3500964	6.54	
		Lt.	3611633	7.03	
	Rear				
		Rt.	3499454	2.68	
		Lt.	3440897	8.17	

Cont'd.

QUARTER PANEL, Cont'd.

STATION WAGON, Cont'd.

SHEET METAL

3.	Panel, Wheelhouse					
	Outer					
		Rt.	3439530	2.5	20.20	
		Lt.	3439531	2.5	33.26	
	Inner					
		Rt.	3439534	2.5	20.20	
		Lt.	3439535	2.5	33.26	
	Panel, Spare Tire Housing					
	Inner *		3440129		11.05	
4.	Lower		3499380		14.90	
			(*Not Illustrated)			
	Housing, Fuel Filler Tube		3440903		7.38	
	Door, Fuel Filler		3440988		8.51	
	Bezel (Vinyl), Filler Opng.		3674155		1.25	
5.	Panel, W/Hsc. to Lock Pillar	Rt.	3440866		3.13	
6.	Plate, Wheelhouse to Sill		3505494-5		3.59	
	Pillar, Rear Door Lock					
7.	Upper					
	Outer		3439550-1		8.82	
	Inner		3439546-7		5.68	
8.	Lower		3439538-9	#	15.35	
			(# 5.0 exc. w/Quarter Removed 3.0)			
9.	Pillar, Tailgate	Upper	3440148-9		2.28	
10.	Lower					
		Rt.	3482528	#	14.90	
		Lt.	2895193	#	9.86	
			(# 5.0 exc. w/Quarter Removed 3.5)			
	Support, T/Gate Pillar to Roof Rail					
11.	Front		3439562-3		20.85	
	Rear		3499606-7		17.85	
	Reinforcement, T/Gate Hinge Pillar					
	Outer	Lt.	3440885		1.83	
	Inner	Rt.	3440884		1.83	
	Filler, Tailgate Opening to Tail Lamp Opening		3499574-5		5.55	
12.	Extension, Tailgate Sill					
	To Pillar	Lt.	3440139		(D) 3.20	
	To Wheelhouse	Lt.	3440931		3.92	

QTR. GLASS & PARTS

Glass, Quarter	(Glass Co.)	(Car Mfr.)
2 Drs. (Stationary) *		
71 Clear NAGS Q4587-8	3582716-7	1.2
Tinted	Use 3582718-9	Use
72 Clear NAGS Q4587-8	3582716-7	1.2
Tinted	3582718-9	
2 Drs. (Roll Down Type) **		
71 Clear NAGS Q4584-5	3445572-3	1.2
Tinted	3445574-5	Glass
72 Clear NAGS Q4777-8	3582708-9	1.2
Tinted	Price 3582710-1	Price
Station Wagon (71-72)		
Clear NAGS Q4596-7	3440204-5	1.3
Tinted	List 3440206-7	List
(* w/Front Frame & Weatherstrip) (**Complete)		
NOTE: 2 Dr. Stationary Glass & Station Wagon Glass Are Partially Cemented in.		
Installation Material - Use As Required.		
Track w/Brkt., Window Slide		
2 Drs.	71 3445672-3	6.01
	72 3582126-7	6.01
Weatherstrip, Glass Belt (2 Drs.)		
Outer	3445698-9	#.3 3.66
Inner		
Upper exc.	3416148-9	#.3 1.58
Fastback	72 3510710-1	#.3 1.58
Lower To 11-70	71 3416368-9	#.3 2.37
After 11-70 71-72	3509916-7	#.3 2.37
	(# R&R w/Glass Removed .2)	
Weatherstrip, Glass Front Frame		
2 Drs.	71 3581170-1	3.27
	72 3582136-7	3.27
Weatherstrip, Glass Lower		
Station Wagon	3500986	1.76
Regulator, Window (2 Drs.)		
Manual	3508396-7	.8 13.27
Electric	3548610-1	.8 16.54
Arm & Slide, Regulator (2 Drs.)	3482562	5.17
Handle, Regulator	2862167	.2 3.95
Motor w/Mechanism, Regulator	3454240-1	.9 46.92

All Labor Operations Are Mitchell Estimated Times.

QTR. MOULDING

QTR. MOULDING, Cont'd.

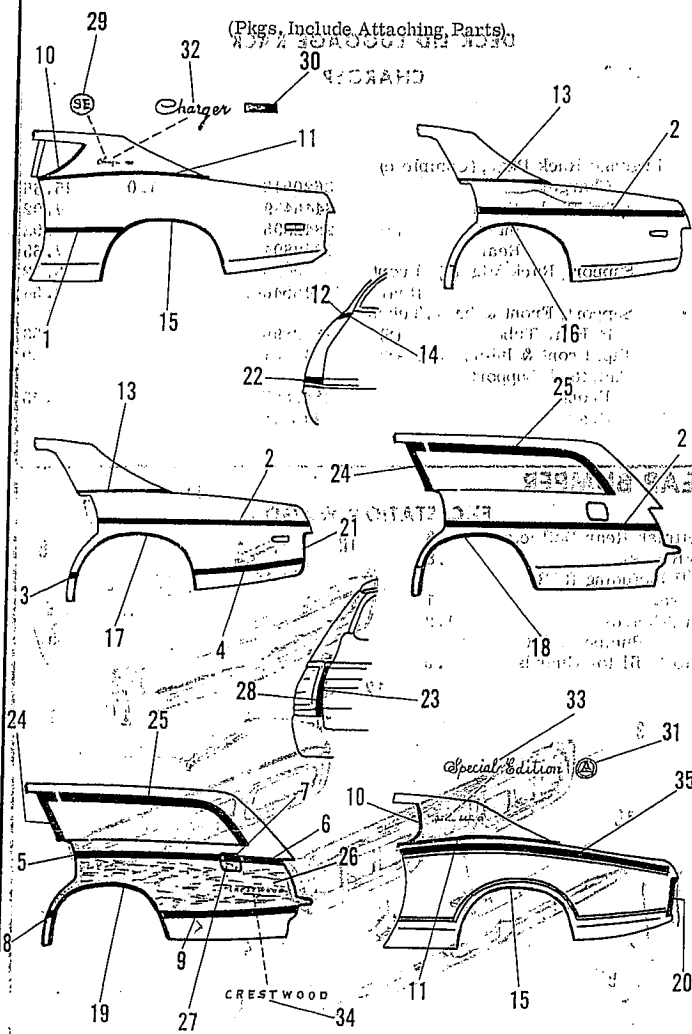

Moulding, Side			
1.	All 2 Drs. To 8-1-71	71-72 3613474-5	2.68
	After 8-1-71 (2) 72	3680870	2.68
4 Drs. exc. Crestwood Station Wagon			
Upper			
	Plain exc.	71 3579456-7	7.03
		72 3685026-7	13.07
	Station Wagon	72 3685024-5	13.64
	Painted exc.	71 3579412-3	5.04
	S/W	71 3579460-1	7.78
	w/Black Insert		
	exc.	3579410-1	7.40
	Custom 4 Dr.	72 3685010-1	14.88
	S/W exc.	71-72 3579458-9	10.03
	Custom	72 3685012-3	17.30
	w/Insert	71 3579998-9	9.09
	exc.		
	Green Blue		
	3620002-3-3620004-5		10.03
	Station Wagon	3620006-7	10.03
	Green Blue		
	3620008-9	010-1	10.03
Lower (Brougham)			
	Front	71 3504702-3	1.54
	Rear	71 3579424-5	4.73
4 Dr. Crestwood Station Wagon			
Upper			
	Right	5579474	6.73
	Left	57579475	5.41
	Front	3579474	1.56
	Rear	3579478	2.42
	Fuel Door	3579478	2.42
	Front	3579478	2.42
	Rear	3579478	5.04
	Lower	72 3685022-3	5.04

Moulding Pkg., Belt (2-Drs.)			
10.	Quarter Glass		
	w/o Vinyl Roof	3579432-3	4.61
	w/Vinyl Roof * exc.	3579448-9	4.80
	"SE"	72 3683798-9	10.57
11.	Front w/o Belt Mldgs.		
	w/Vinyl Roof *	3579446-7	4.16
	w/Belt Mldgs.	3579434-5	5.84
12.	Rear	3579444-5	2.98
Moulding Pkg., Belt (4 Dr.)			
13.	w/Vinyl Roof * Front	3620264-5	2.61
14.	Rear	3579572-3	2.98
(*Or 2 Tone Paint) (#exc. w/Inner Trim Removed .3)			
Moulding Pkg., Wheel Opening			
15.	2 Drs.	3504736-7	3.58
16.	4 Dr. Sed. exc.	3504739-1	3.58
17.	Brougham	71 3579420-3504705	4.73
18.	S/W exc.	3504732-3	3.58
19.	Crestwood	3504712-3	4.02
Moulding Pkg., Bumper Outline			
20.	Charger	3504764-5	9.13
21.	Brougham	71 3504772-3579427	9.89
(# w/Bumper Removed)			
Moulding Pkg., End (Rear)			
	Charger	3504758-9	1.68
	Custom 4 Dr. Sedan	3620262-3	5.61
(# w/Bumper Removed)			
23. Panel, End Extension Finish			
	Custom	71 3506000-1	4.36
Mldg. Pkg., Window Opening (S/W)			
24.	Front		
	Stainless	3620084-5	3.85
	Galvanized	3620086-7	1.38
25.	Upper & Rear		
	Stainless	3620082-3	8.82
	Galvanized	3620088-9	6.13
Overlay, Wood Grain (Crestwood S/W)			
26.	Side	3680107	23.33
27.	Fuel Door	3570002	5.29
28.	End & Extension	3570002	5.29
(# 1.5 w/Mldgs. Removed & After Painting)			
Medallion, Side Upper			
29.	71 Charger "SE"	3613823	5.17
30.	72 Charger exc. "SE"		
	w/o Vinyl Roof	3680357	2.04
	w/Vinyl Roof	3680357	2.04
	72 Charger "SE"	3613823	5.17
(# 1.0 exc. w/Headliner Loose .200)			
Nameplate, Side (72 Only)			
32.	"Charger"		
	w/o Vinyl Roof	3680354-5	2.49
	w/Vinyl Roof	3680354-5	2.49
33.	"R/T"		
	w/o Vinyl Roof	(2) 3680356	1.95
	w/Vinyl Roof	(2) 3613698	1.80
34.	"Special Edition"		
	w/o Vinyl Roof	(2) 3680358	2.19
	w/Vinyl Roof	(2) 3613273	2.49
35.	"Crestwood"	(2) 3570365	4.19
Tape Pkg. Stripes*			
	71 Super Bee, R/T		
	w/o Door Mirror	3685200-1	22.55
	w/Door Mirror	3685202-3	22.37
	71 Charger SE		
	Up to 12-1-70	Blue	3612953
		Green	3612954
		Black	3613525
		White	3613526
	After 12-1-70	Blue	3613526
		Gold	3612955
		Black	3612956
		White	3612957
	72 exc. Charger (SE)	Blue	3685306-7
		White	308310-1
		Black	312-3
		Gold	312-3
(*Pkg. Incl. Panels & Door for Onlays)			
(Deck Lid Extension - See Deck Lid.)			
(# Time for Quarter Only)			
(NOTE: Check Local Dealer for Availability of Separate Quarter Only Tapes.)			

Cont'd.

LUGGAGE LID

- Refinish Lid 2.5
- Add to R&R
 - to Drill for Each Mldg. .2
 - to Drill for Nameplate .2
 - w/Spoiler 1.0
 - w/Luggage Rack 1.0
 - w/Decal .3
 - w/Stripe Tape .6
- Stripe tape or decal time does not include removal of old tape or decal.

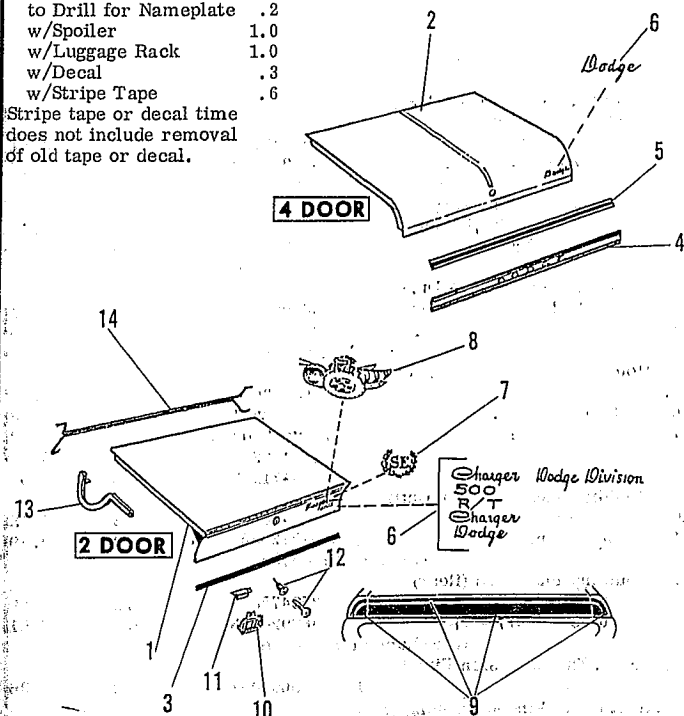

1. Lid, Deck				
2. 2 Drs.	3482013	1.0	146.75	
4 Dr.	3482001	1.0	146.75	
Spoiler w/Stanchions, Lid				
71 2 Drs.	3570208	1.0	72.29	
Mounting Pkg., Spoiler				
71 2 Drs. (For Field Install.)	3579669		10.47	
Moulding (Pkg., Lower Edge				
3. Charger 500 & "SE" *	3505544	.3	4.15	
4. 4 Dr. (w/Letters "Dodge")	71 3579476		6.60	
5. 4 Dr. (Black)	72 3685516		7.58	
(*Includes Bracket)				
6. Nameplate, Lid				
71 "Charger-Dodge Division"	3570035	.2	4.13	
"500"	3506413	.2	1.83	
"R/T"	3504809	.2	2.68	
"Dodge" (4 Dr.)	3680384	.2	2.43	
72 "Charger" exc.	3580687	.2	2.54	
SE After '10-1-71	3680687	.2	2.54	
"Dodge" (2 Drs.)	3613272	.2	1.83	
"Dodge" (4 Dr.)	3680384	.2	2.43	
7. Medallion, Lid				
71 Charger SE	3504811	.2	5.17	
8. Decal, Lid "Super Bee"	71 3570036	.3	.72	
9. Tape, Stripe (Pkg.)*				
72 Charger exc. SE Black	3680233	.6	11.82	
(*Pkg. Includes Qtr. Panel Extension Tapes)				
10. Lock or Latch				
w/o Power Release	2167260	.3	6.01	
w/Power Release (Partial)	2428275	.4	6.08	
(Complete)	3586435	.6	30.01	
11. Striker, Lock	2244149	.3	.99	
12. Cylinder & Key Pkg., (Includes Glove Box)	3620494	#	7.59	
# R&R Lid or Glove Box .3				
13. Hinge, Lid	3482536-7	#	6.22	
# .7 exc. w/Lid Removed .4				
14. Bar, Hinge Torsion				
2 Drs. exc.	3445882-3	.3	4.13	
71 w/Spoiler	N.A.	.3	N.A.	
4 Dr.	3445134-5	.3	4.13	
Weatherstrip, Lid	3616754	.7	9.09	

Cont'd.

LUGGAGE LID, Cont'd.

DECK LID LUGGAGE RACK CHARGER

Luggage Rack Pkg., (Complete) Charger	3620518	1.0	45.65
Tube, Rack Front	3446439		4.92
Inter. (2)	2842895		4.92
Rear	2842894		7.65
Support, Rack Mtg. (2) Front	3445415		3.92
Rear	3446546-7		4.54
Support, Front & Inter. Tubes to Rear Tube (8)	2842896		1.83
Tip, Front & Inter. Tube (8)	2842901		.99
Pad, Rack Support			
Front	2842897		.45
Rear	3445418		.45

REAR BUMPER

- Refinish Rear Deflector R&R Assy. O/H including R&R exc. 1.1
- w/Guards 1.2
- Add to Bumper R&R to Drill for Guards .5

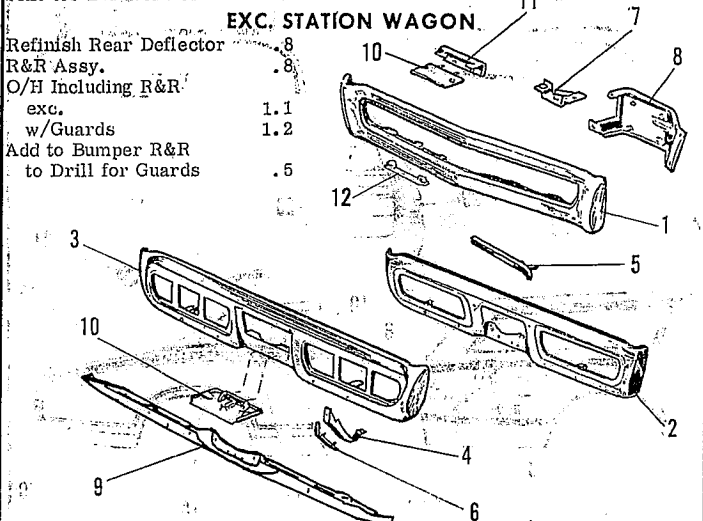

Face Bar								
1. 2 Drs.								
Chrome To 6-71	71 3595109	1.1	69.17					
After 6-71	71-72 3595109	1.1	69.17					
Painted Red	71 3464466	1.1	81.42					
Avocado Yellow	Blue Plum Green							
3464467	468 469 470 471	1.1	81.42					
2. 4 Dr.	71 3464400	1.1	69.17					
3. 72	3595185	1.1	69.17					
Guard, Bar (2)								
4. Vertical	2 Drs. 3464438	.4	11.45					
4 Dr.	3464412	.4	11.45					
5. Horizontal	2 Drs. N.A.	.5	N.A.					
6. Cushion, Guard (Vertical) (2)								
2 Drs.	3464440		2.43					
4 Dr.	3464414		2.16					
Strut, Vertical Guard	4 Drs. 3464419		.84					
7. Brace, Vertical Guard	3464462-3		1.04					
8. Support, Bar	2 Drs. 3464430-1		10.70					
4 Dr.	3464408-9		10.70					
9. Deflector, Rear Stone								
2 Drs. exc.	3505696	1.0	17.85					
w/Tail Pipe Extensions	3570080	1.0	17.85					
4 Dr.	3505716	1.0	17.85					
10. Panel, License Mounting	3464244		5.50					
11. Bracket, Panel Mounting								
2 Drs.	71 3464434		1.70					
72	3595197		1.70					
12. Closure, License Plate to Bar								
2 Drs.	71 3464432		5.23					
w/o T/Lamp Dress	72 3595194		5.23					
w/Tail Lamp Dress	72 3595199		5.23					

Cont'd.

OCTOBER 10 1974

DODGE

CORONET & CHARGER 1971-72

REAR BUMPER, Cont'd.

STATION WAGON

R&R Bumper Assy.
O/H, Incl. R&R

1. Face Bar To	6-71	71	3464275	1.1	75.38
After 6-71	71-72		3595106	1.1	75.38
2. Support, Bar			3464282-3		7.22
3. Filler, Bar to Body			3464284-5		2.16
4. Pad, Impact	(2)		2856588		1.62

REAR BODY, Cont'd.

STATION WAGON, Cont'd.

3. Support, Sill Opening	(2)	71	2860194		.99
	(2)	72	3720272		1.04
4. Crossmember, Rear, Floor Pan Rear			3440842		10.86
5. Pan, Rear Floor			3440566		55.17
6. Header, Roof Rear			3482547		22.62

(#2.5 w/ Roof Panel Removed)

REAR BODY

EXC. STATION WAGON

Refinish Lower Panel 1.0
Upper Panel 1.0
Add to Panel R&R to Drill for Each Mldg. .2

1. Panel, Lower (Below Lid)					
2 Drs.			3445780		12.83
4 Dr.			3504310		23.10
(#5.0 exc. w/ One Qtr. Rem. 3.5, w/ Both Qtrs. Rem. 2.5)					
Support, Lower Panel					
2 Drs.	(2)		3615061		3.13
4 Dr.	(2)		3445098		3.13
Support, Lower Panel to Bumper					
2 Drs.	(2)		3504166		4.97
4 Dr.	(2)		3446048		3.59
Reinforcement, Lower Panel					
2 Drs.			3505470		12.02
Extension, Lower Panel Reinf.					
2 Drs.	(2)		3504312-3		3.27
4 Dr.			3446524-5		2.62
2. Panel, Upper: (Above Lid)					
2 Drs.			3445777		14.19
4 Dr.			3445086		14.19
Moulding Pkg., Upper Panel					
2 Drs.			3579450-1		3.92
4 Dr.			3579428-9		3.92

(w/ Vinyl Roof or 2 Tone Paint)

FUEL TANK

TYPICAL

1. Tank, Fuel					
exc. To 3-72	71-72		3404951	1.9	64.83
After 3-72	72		3642103	1.9	66.89
S/W To 4-72	71-72		3466153	2.0	57.00
After 4-72	72		3642170	2.0	56.74
2. Cap, Fuel Filler (Non-Locking)					
To 2-72			3466825		2.17
After 2-72			3780670		2.17
3. Tube, Fuel Filler					
2 Drs.	71		3466426		4.19
To 2-72	72		3466330		4.13
After 2-72	72		3642126		4.19
4 Drs. To 2-72	71-72		3404958		4.58
After 2-72	72		3642120		4.58
4. Grommet, Filler Tube exc. Station Wagon			2880481		.99
5. Strap, Tank Support exc.	(2)		3466333		2.26
Station Wagon Front			3404973		1.88
Rear			3404972		2.43
Shield, Tank Stone (S/W)			3499626		11.10
Separator, Fuel Vapor exc. S/W To 3-72	71-72		3466835		30.46
After 3-72	72		3642105		8.42
6. Gauge, Tank Unit exc. S/W exc.	71		3514446	1.0	14.40
	72		3780566	1.0	14.40
w/440	71		3514443	1.0	14.40
	72		3780567	1.0	14.40
Station Wagon			3514447	1.3	14.40

STATION WAGON

1. Panel, Tailgate Opening Sill					
Upper			3500938		15.24
Lower			3440567		17.71
(#w/ Gate Removed)					
2. Pad, Sill Step			3416654		2.37
3. Brace, Sill Panel (at Lock Opng.)			3499690		1.04
To 3-72	71-72		3499690		1.04
After 3-72	72		3720274		1.01

REAR AXLE

TYPICAL

1. Drum, Rear Brake	10		3580553		24.71
	11		3549842		28.72
2. Support, Rear Brake	10		2880602-3699601		12.02
	11		2880646-7		12.68
Hose, Rear Brake	71		3461728		3.52
	72		3466788		6.39

(#Each Additional .3, Includes Bleed Brakes)

Cont'd.

Cont'd.

REAR AXLE, Cont'd.

3. Shaft, Rear Axle			
w/7-1/4" Ring Gear			
71 6 Cyl. exc. S/W	3432792	#1.5	34.70
w/8-1/4" Ring Gear			
71 w/1.40" Brg.	3507475	#1.3	34.70
w/1.62" Brg.	2931864	#1.3	34.70
72 exc.	2931864	#1.3	34.70
S/W	3507172	#1.3	34.70
w/8-3/4" Ring Gear exc.	3432830	#1.3	34.70
S/W	3432786	#1.3	34.70
w/9-3/4" Ring Gear	3507507-8	#2.2	59.20
(#Includes R&R Bearings & Seals.)			
4. Bearing, Axle Shaft			
w/7-1/4" Ring Gear	71 3420091	#	16.25
w/8-1/4" Ring Gear		#	
1.40 I.D., 2-1/4 O.D.	71 2852949	#	6.40
1.62 I.D., 2-17/32 O.D.	71-72 2931851	#	7.25
w/8-3/4, 9-3/4" R/Gear	3508366	#	17.75
(#Use Axle Shaft Time)			
5. Oil Seal, Axle Shaft			
w/7-1/4" Ring Gear	71 2852948		1.95
w/8-1/4" Ring Gear			
1.40" I.D.	71 2852948		1.95
1.62" I.D.	71-72 2931875		2.05
w/8-3/4" Ring Gear			
Outer	2404216		2.00
Inner	3621967		2.85
w/9-3/4" Ring Gear			
Outer	2404216		2.00
Inner	2852574		2.50
6. Housing, Rear Axle			
w/7-1/4" Ring Gear			
71 6 Cyl. exc. S/W	3507500	3.9	134.09
w/8-1/4" Ring Gear			
71 w/1.40" I.D. Brg.	3507527	5.0	134.09
w/1.62" I.D. Brg.	3507168	5.0	134.09
72 w/o Sure Grip exc.	3507168	5.0	134.09
S/W	3507711	5.0	123.07
w/Sure Grip (2.71 Ratio)	3507712	5.0	137.47
w/8-3/4" Ring Gear exc.	3507502	5.0	123.42
S/W	3507501	5.0	123.42
w/9-3/4" Ring Gear	3507530	7.0	247.20

REAR SUSPENSION, Cont'd.

Spring, Rear (Heavy Duty)			
exc. S/W 6 Cyl.	3004655	1.1	42.95
V8	2585640	1.1	43.24
Station Wagon 2 Seat	3514965	1.1	48.66
3 Seat	3514966	1.1	48.66
Spring, Rear (Extreme Duty)			
71 w/318, 383 2 Bbl.	3004767	1.1	65.46
w/383 4 Bbl., 426, 440	3549073-2	1.1	65.46
2. Main Leaf, Spring (Standard)			
exc.	3400876	1.6	16.56
Super Bee, 440 (72)	3400872	1.6	17.84
w/426, 440	71 3400874	1.6	17.15
S/Wagon	3400949	1.6	18.41
Extreme Duty	3400874	1.6	17.15
3. Shackle & Bushing Pkg., Spring			
exc.	3004823		3.41
Station Wagon	71 3004824		3.75
	72 3514978		3.58
4. Bushing, Shackle (8)			
	1400269		.52
5. Bushing, Spring Front exc.			
	1948869		2.24
Extreme Duty	2403245		2.19
6. Shock Absorber w/Bshgs., Rear			
1" Dia. Standard	3643605	.7	14.90
1" Dia. Heavy Duty *	71 3643605	.7	14.90
	72 3643605	.7	14.90
1-3/8" Dia. Extra Duty	71 3402273	.7	21.15
2-3/8" Dia. Super Duty	71 3402274	.7	21.15
7. Bushing, Shock Upper (2)			
	2201554		.98
8. Lower (2)			
	1319902		.46
Bar w/Bshgs., Rear Sway w/o 9-3/4" Axle			
To 1-72	71-72 3643980		33.41
After 1-72	72 3543980		33.41
w/9-3/4" Axle	3643501		32.03
Insulator, Link	(4) 2071604		.39
Retainer, Link Insulator	(4) 2071611		.18
Bushing, Bar	(2) 2269709		.99
Retainer, Bar-Bshg.	(2) 3643506		.66

REAR SUSPENSION

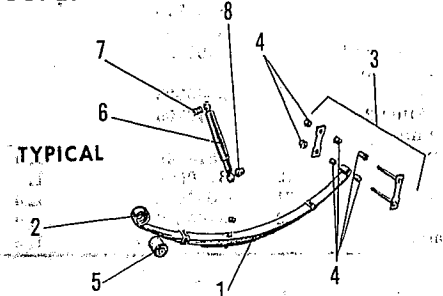

TYPICAL

1. Spring, Rear (Standard)			
71 2 Drs.			
w/225, 318	3004651	1.1	42.95
w/340, 383 exc. Super Bee	3004766	1.1	42.95
w/340, 383 Super Bee			
w/o Trailer Pkg.	3004655	1.1	42.95
w/Trailer Pkg.	2585640	1.1	43.24
w/426, 440	3004768-7	1.1	65.46
72 2 Drs.			
exc.	3004651	1.1	42.95
2 Dr. H.T. w/340, 400	3004766	1.1	42.95
All w/440 8-3/4" Rear Axle	2585640	1.1	43.24
9-3/4" Rear Axle	2585641	1.1	46.77
71 4 Drs. w/225, 318	3004766	1.1	42.95
w/383	3004652	1.1	42.95
72 4 Drs. w/225, 318	3004766	1.1	42.95
w/400	3004652	1.1	42.95
71-72 Station Wagon			
2 Seat To 10-1-70	3514246	1.1	43.24
From 10-1-70	3514245	1.1	43.24
3 Seat To 10-1-70	3514245	1.1	43.24
From 10-1-70	3549064	1.1	43.24

REAR LAMP

TAIL, STOP, DIRECTIONAL & BACK-UP LAMP
1971
2 DOOR
w/CHROME BUMPER

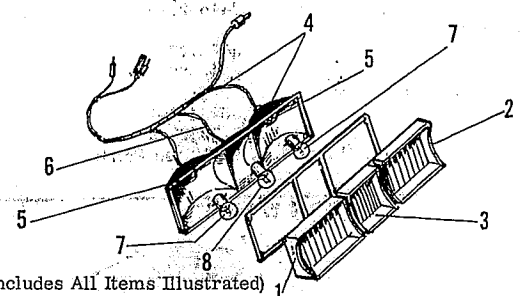

(Assy. Includes All Items Illustrated)

Lamp Assembly			
Charger, Super Bee	3478748-9	.6	32.33
SE	3478796-7	.6	32.33
Lens & Gasket Pkg.			
1. Tail Lamp Outer	3514318-9	.4	4.83
2. Tail Lamp Inner	3514316-7	.4	4.83
3. Back-Up Lamp	3514320-1	.4	2.54
4. Housing & Gasket *			
Socket, Bulb			
5. Tail Lamp *			
6. Back-Up Lamp	2983279		1.25
Bulb			
7. Tail Lamp (1157)	9417867		.57
8. Back-Up Lamp (1156)	9417866		.59
(*Not Serviced Separately, Use Lamp Assy.)			

Cont'd.

Cont'd.

SEP 1, 1974

DODGE

CORONET & CHARGER 1971-72

REAR LAMP, Cont'd.

REAR LAMP, Cont'd.

TAIL, STOP, DIRECTIONAL & BACK-UP LAMP, Cont'd.

TAIL, STOP, DIRECTIONAL & BACK-UP LAMP, Cont'd.

1971

1972

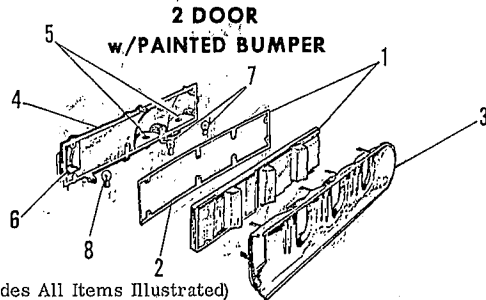

(Assy. Includes All Items Illustrated)

Lamp Assembly	3478854-5	.6	37.40
1. Lens & Gasket Pkg.	3514358-9	.4	10.01
2. Gasket, Lens	3478864		1.38
3. Bezel	3478862-3		19.75
4. Housing *			
5. Socket, Bulb			
6. Tail Lamp *			
7. Back-Up Lamp	2983279		1.25
8. Bulb			
9. Tail Lamp (1157)	9417867		.57
10. Back-Up Lamp (1156)	9417866		.59

(*Not Serviced Separately, Use Lamp Assy.)

4 DOOR

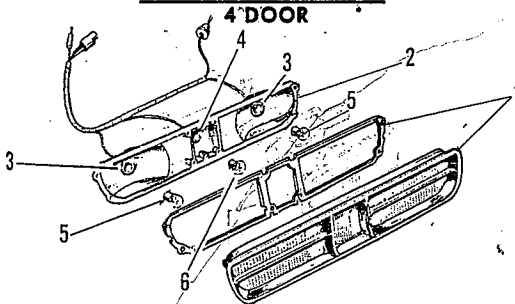

(Assy. Includes All Items Illustrated)

Lamp Assembly	3478686-7	.6	23.68
1. Lens & Gasket Pkg.	3514322-3	.4	11.87
2. Housing *			
3. Socket & Cable, Tail Lamp *			
4. Socket, Back-Up Lamp	2983279		1.25
5. Bulb Tail Lamp (1157)	9417867		.57
6. Back-Up Lamp (1156)	9417866		.59

(*Not Serviced Separately, Use Lamp Assy.)

1972
2 DOOR

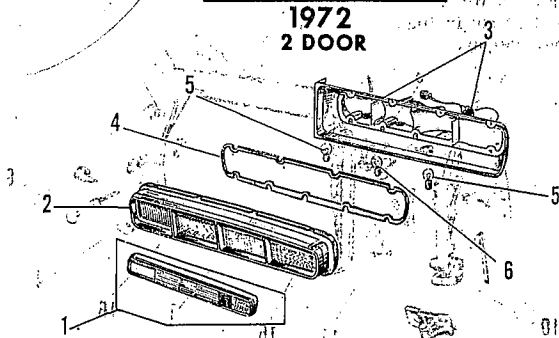

(Assy. Includes All Items Illustrated)

Lamp Assembly			
exc. Fastback			
w/o Dress Up Pkg.	3587172-3		32.33
w/Dress Up Pkg.	3587446-7		42.48
Fastback (SE) (#w/Bumper Assy. Removed)	3587252-3		40.46

Cont'd.

2 DOOR, Cont'd.

Lamp Assembly, Cont'd.

Lens & Gasket Pkg.			
1. exc. Fastback			
w/o Dress Up Pkg.	3620796-7	.2	12.33
w/Dress Up Pkg.	3514358-9	.2	10.01
2. Fastback (SE)	3620798-8	.2	21.26
3. Housing w/Socket & Cable *			
Bezel ** w/Dress-Up Pkg.	3587448-9		18.96
Gasket, Lens **			
All w/o Dress Up Pkg.	3587180		1.25
exc. Fastback			
w/Dress Up Pkg.	3478864		1.38
4. Gasket, Housing	3587180		1.25
5. Bulb, exc. (1157) (4) (1) 9417867			1.57
6. Back-Up (1156) (2) 9417866			1.59

(*Not Serviced Separately, Use Lamp Assy.)
(**Not Illustrated)

4 DOOR

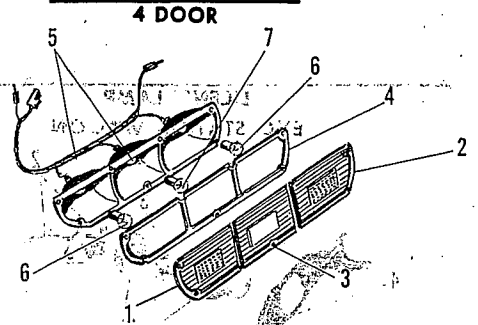

(Assy. Includes All Items Illustrated)

Lamp Assembly	3587358-9	#.2	24.02
(# w/Bumper Assy. Removed)			
Lens, Tail, Stop & Signal			
1. Rt. Outer, Lt. Inner (2)	3587217		2.93
2. Rt. Inner, Lt. Outer (2)	3587218		2.93
3. Lens, Back-Up (2)	3587219		3.59
4. Gasket, Lens	3587216		1.25
5. Housing w/Socket & Cable *			
6. Bulb, exc. (1157) (4) 9417867			1.57
7. Back-Up (1156) (2) 9417866			1.59

(*Not Serviced Separately, Use Lamp Assy.)

TAIL, STOP & DIRECTIONAL LAMP
(w/SIDE MARKER LAMP)

STATION WAGON

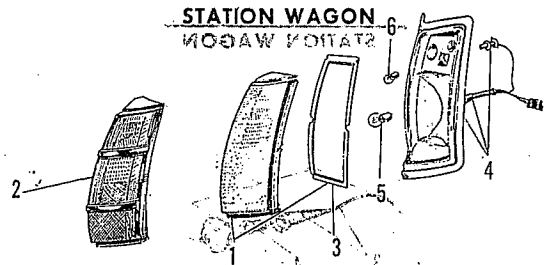

Lamp Assembly			
71 Coronet, Custom*	3514418-9	.4	26.66
Custom**, Crestwood	3579198-9	.4	26.76
72 exc.	3620742-3	.4	33.66
(*After 9-70) (**To 9-70)			
1. Lens & Gasket Pkg.	71 3514420-1		6.80
2. 72 3620740-1			11.94
3. Gasket, Lens	3478974		1.66
4. Housing w/Socket & Cable *			
5. Bulb, exc. (1157)	9417867		.57
6. Marker Lamp (1893)	9416927		.26

Cont'd.

REAR LAMP, Cont'd.

BACK-UP LAMP
STATION WAGON

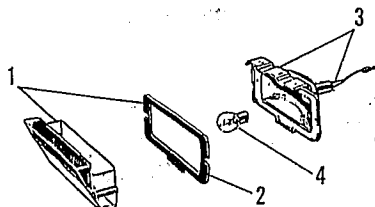

(Assy. Includes All Items Illustrated)

NOTE: For Other Models, See Tail Lamp

Lamp Assembly	3478802	.3	7.38
1. Lens & Gasket Pkg. (2)	3579186		2.74
2. Gasket, Lens or Lamp.Mtg.	3478818		.53
3. Housing w/ Cable & Socket *			
4. Bulb (1156)	9417866		.59

(*Not Serviced Separately, Use Lamp Assy.)

LICENSE LAMP
EXC. STATION WAGON

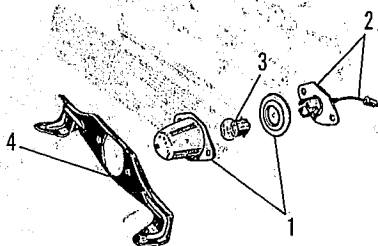

(Assy. Includes All Items Illustrated)

Lamp Assembly	3479304	.3	6.01
1. Lens & Gasket Pkg.	3620734		1.04
2. Socket & Plate *			
3. Bulb (67)	142450		.28
4. Bracket, Mounting * Cover w/ Stud, Lamp 2 Drs.	3615103		2.37

(*Not Serviced Separately, Use Lamp Assy.)

STATION WAGON

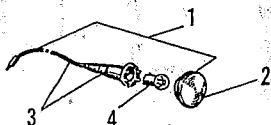

(Assy. Includes All Items Illustrated)

1. Lamp Assembly	3479304	.2	6.01
2. Lens	3620734		1.04
3. Socket & Cable *			
4. Bulb (67)	142450		.28

(*Not Serviced Separately, Use Lamp Assy.)

Cont'd.

REAR LAMP, Cont'd.

SIDE MARKER LAMP
EXC. STATION WAGON

1971

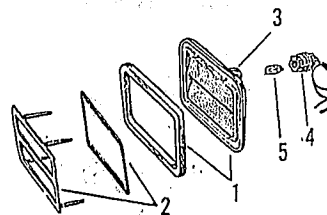

(Assy. Includes All Items Illustrated)

Lamp Assembly	2 Drs.	3579153	.3	4.70
	4 Dr.	3579151	.3	4.97
1. Lens & Gasket *				
2. Bezel & Gasket *				
3. Housing *				
4. Socket & Cable		3513686		.99
5. Bulb (194)		9421330		.27

(*Not Serviced Separately, Use Lamp Assy.)

1972

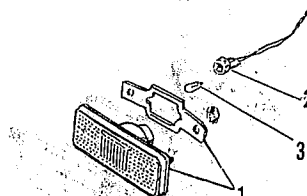

1. Lamp Assembly *	3587440	.3	1.64
	(*Includes Lens, Housing & Gasket)		
2. Socket & Cable	3588314		2.88
3. Bulb (194)	9421330		.27

REAR GATE

Refinish O.S. 2.0
Jams, Add .5
Add to Gate R&R
w/Electric Lift .6
to Drill for Each Mldg. .2
Overlay time does not include
removal of old overlay.

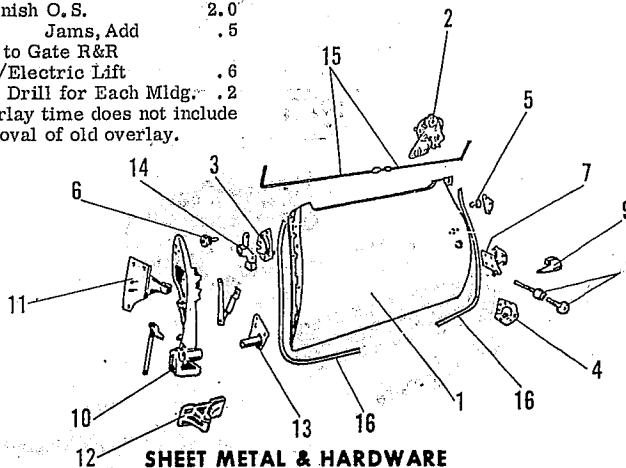

SHEET METAL & HARDWARE

1. Tailgate				
Manual	3482297	4.5	174.27	
Electric	3482284	5.0	174.27	
Cover, Inside	3440266	.3	11.82	

Cont'd.

OCTOBER 1, 1974

DODGE

CORONET & CHARGER

1971-72

REAR GATE, Cont'd.

SHEET METAL & HARDWARE, Cont'd.

Latch or Lock				
2.	Upper w/Manual Gate * Rt.	3548268	#	19.15
	w/Elec. Gate * Rt.	3508058	#	19.15
	All ** Rt.	3670078	#	19.15
3.	All Lt.	3508059	#	6.86
4.	Lower All Rt.	3508084	#	7.65
(*Up to 11-15-70) (**After 11-15-70)				
(#One .7, All 1.0)				
Striker, Latch				
5.	Upper Rt.	3508046	.2	2.22
6.	Lt.	3508801	.2	2.22
7.	Lower Rt.	3454480	.2	2.68
Control, T/Gate Latch Locking 3508069 4.97				
Control, T/Gate Latch Remote				
Manual 3508083 .4 7.27				
Electric 3508815 .4 7.27				
8.	Cyl. & Keys Pkg. (Incl. Doors & Ignition)			
	Manual w/o Tilt Wheel 71	3508876	#	12.36
	72	3670674	#	12.62
	w/Tilt Wheel	3548957	#	10.27
	Elec. w/o Tilt Wheel 71	N.A.	#	N.A.
	72	3695162	#	13.35
	w/Tilt Wheel	3548958	#	10.27
(#R&R Tailgate .7, Door .6, Ignition 1.0)				
9.	Handle, Tailgate Door			
	Outside Rt. 71	3508662	.7	10.98
	Rt. 72	3586858	.7	10.98
Hinge, Tailgate				
10.	Lower (Gate Half) 3696284 1.8 50.20			
11.	Upper (Door Half) Lt. 3548019 1.8 16.94			
Support, Hinge				
12.	Lower (Gate Half) Lt. 3508245 1.8 4.70			
13.	Upper (Door Half) Lt. 3508663 1.8 7.38			
14.	Wedge, Tailgate Door Lt. 3548025 11.24			
Link, Tailgate Support 3508667 1.97				
Bar, Tailgate Hinge Torsion 3508660 1.6 5.09				
16.	Weatherstrip, Tailgate Opening Lower 3581168-9 .3 3.99			

MOULDINGS & TRIM

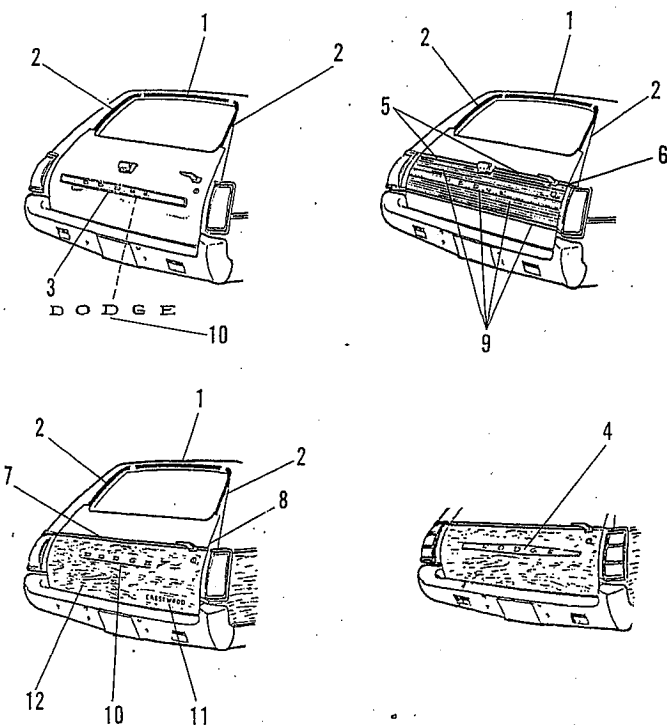

Cont'd.

REAR GATE, Cont'd.

MOULDINGS & TRIM, Cont'd.

(Pkgs. Include Attaching Parts)

1.	Moulding, Opening Upper	3440120	.3	5.04
2.	Moulding, Upper Pillar	3440194-5	.3	3.99
Moulding Pkg., Nameplate				
3.	Coronet	71 3579477	.4	32.17
4.	Crestwood	72 3613209	.4	25.49
Moulding Pkg., Tailgate Upper w/Manual Window				
5.	Center	71 3579480-1	.4	4.52
	Rt. 72	3683391	.4	3.92
	Lt. 72	3683325	.4	4.52
6.	Outer Rt.	3620266	.4	2.81
w/Electric Window				
7.	Right	All 3620266	.4	2.81
8.	Left	71 3579478	.4	6.01
	72	3683402	.4	6.01
9.	Panel Pkg., Finish (Custom) w/Manual Window			
	71	3683208		29.41
	72	3680386		29.41
w/Electric Window				
	71	3683209		29.41
	72	3680385		29.41
10.	Letters, Name			
	71 Crestwood "D"	(2) 3612452		.92
	72 Coronet "D"	(2) 3680245		.92
	71-72 "O"	"G"	"E"	
	3612453	454	455	.92
11.	Nameplate, "Crestwood" 71 3570365 4.19			
12.	Overlay, Wood Grain (Crestwood) 3680107 # 23.33			
(# 1.5 w/Midgs. Removed & After Painting)				

GLASS & PARTS

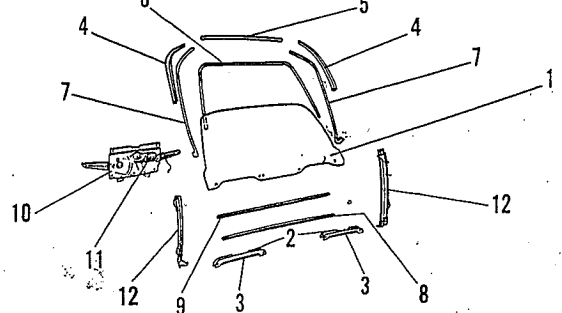

1.	Glass, Tailgate (Glass Co.)			(Car Mfr.)
	Clear NAGS B4598	Use 3581900	.9	Use
	Tinted	Glass Price List 3581901		Glass Price List
2.	Frame w/Channel, Glass Lower	3581172		2.74
3.	Gasket, Lower Frame	(2) 71 3440269		1.04
	(4) 72 3581844			.11
Retainer, Glass Opening Weatherstrip				
4.	Side	3581208-9		7.52
5.	Upper	3440126		.99
Weatherstrip, Glass Opening				
6.	Outer	3582996		11.24
7.	Inner	3582998-9		12.02
Weatherstrip, Glass Belt				
8.	Outer To 12-70	71 3499783	.2	3.13
9.	After 12-70	71-72 3581909	.2	3.13
9.	Inner	3499781	.2	4.64
10.	Regulator, Window			
	Manual	3586393	.8	26.80
	Electric To 7-72	3586444	#1.4	33.08
	From 7-72	3695501	#1.4	33.08
(# Incl. R&R Motor & Mechanism)				
Handle, Manual Regulator				
	Up to 1-1-71	3508674	.7	20.53
	After 1-1-71	3670003	.7	20.53
11.	Motor, Electric Regulator 3586564 46.16			
	Drive, Electric Regulator	3548134		22.67
	Coupling, Motor to Drive	1778955		3.47
12.	Channel w/Brkt., Glass Run Lwr. 3440246-7 6.47			

Main body of text on the left side of the page, consisting of several paragraphs of faint, illegible text.

Continuation of the main body of text on the left side, appearing as a list or series of entries.

Main body of text on the right side of the page, consisting of several paragraphs of faint, illegible text.

